

SILT FENCE TYPE MS
(MACHINE SLICED)

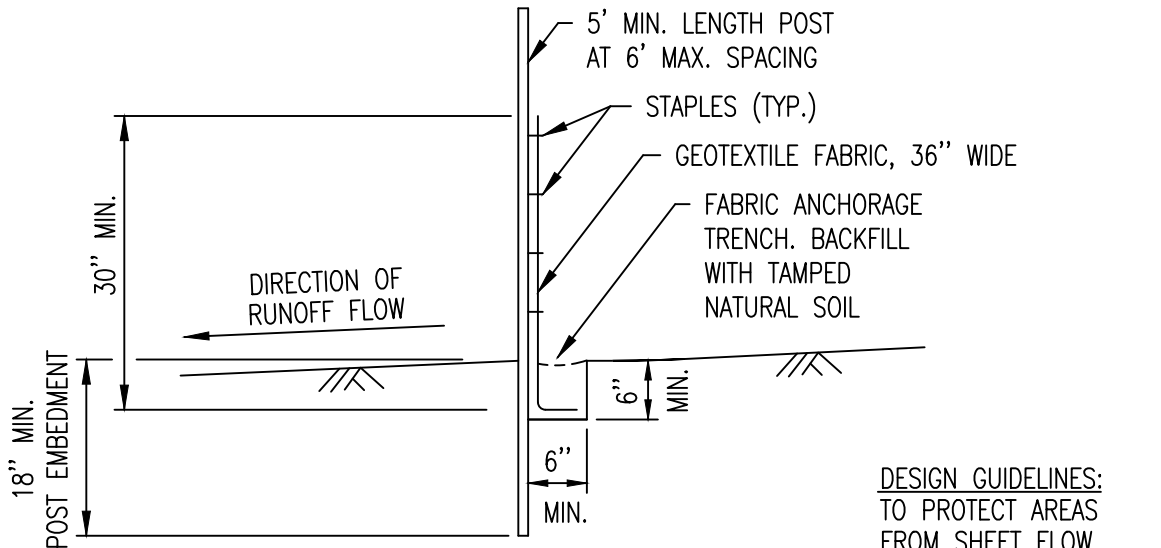

SILT FENCE TYPE PA
(PREASSEMBLED)

DEPARTMENT OF PUBLIC WORKS
CITY OF ROCHESTER, MINNESOTA
SILT FENCE DETAILS
TYPES MS AND PA

Dylan S. Dahl
CITY ENGINEER

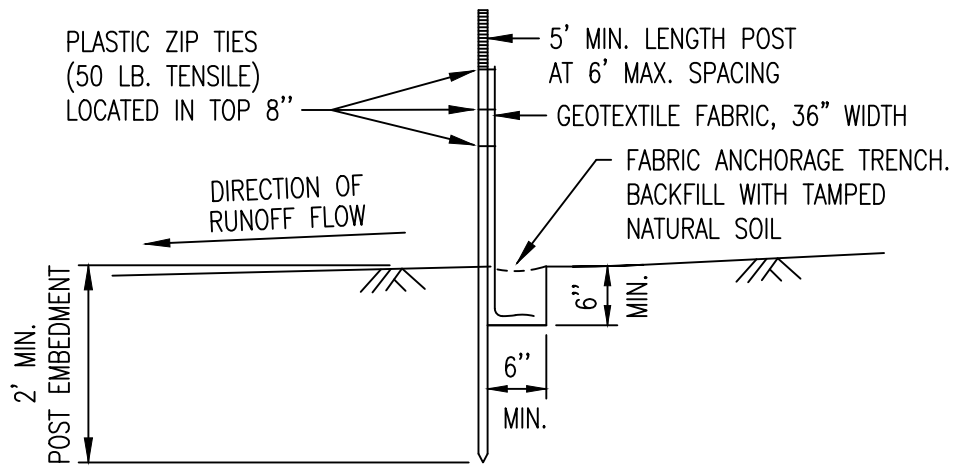

**SILT FENCE TYPE HI
(HAND INSTALLED)**

DESIGN GUIDELINES:
TO PROTECT AREAS
FROM SHEET FLOW.
MAXIMUM CONTRIBUTING
AREA: 1 ACRE

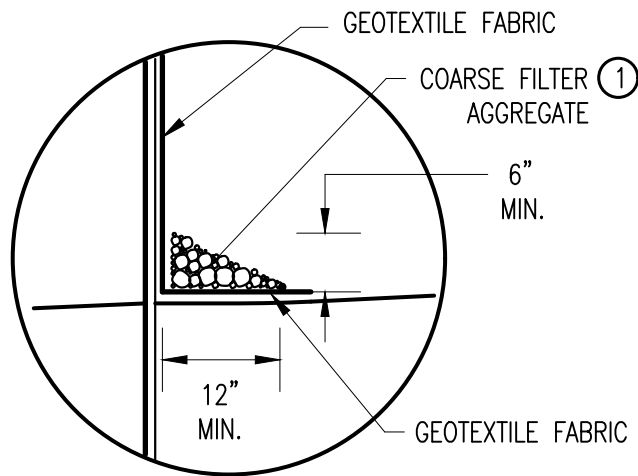

OPTIONAL METHOD

① COARSE FILTER AGGREGATE (MN/DOT SPEC. 3149)
SHALL BE INCIDENTAL.

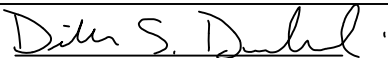
DEPARTMENT OF PUBLIC WORKS CITY OF ROCHESTER, MINNESOTA SILT FENCE DETAILS			
 CITY ENGINEER			
SHT 2 OF 3 SHTS	DATE REVISED 1/1/23	PLATE NO. 7-01	REV. F

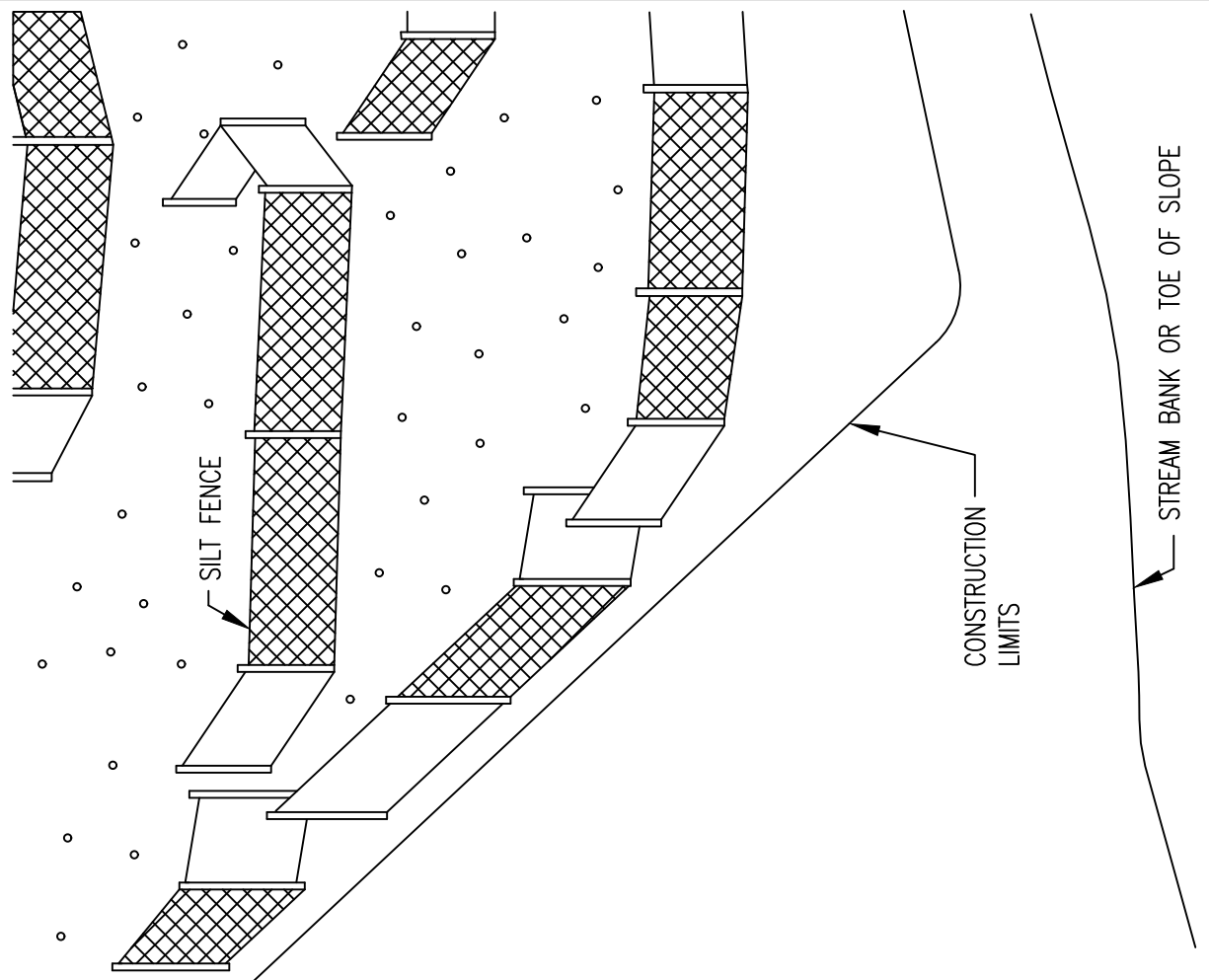

PERSPECTIVE VIEW

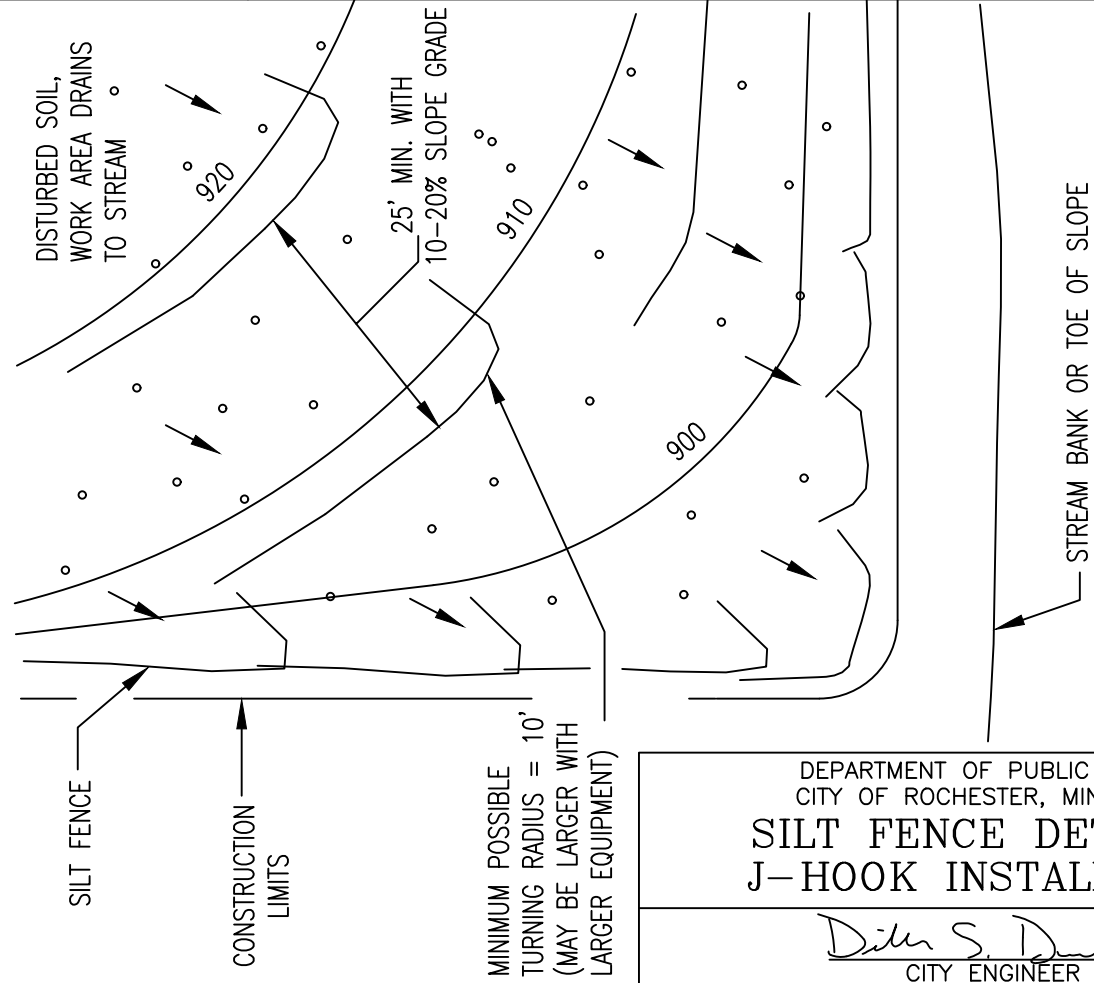

PLAN VIEW

DEPARTMENT OF PUBLIC WORKS CITY OF ROCHESTER, MINNESOTA SILT FENCE DETAILS— J-HOOK INSTALLATION			
<i>Dimitri S. Dahl</i> CITY ENGINEER			
SHT 3 OF 3 SHTS	DATE REVISED 1/1/23	PLATE NO. 7-01	REV. F

REFERENCE: MN/DOT SPEC. 2573 & 3886

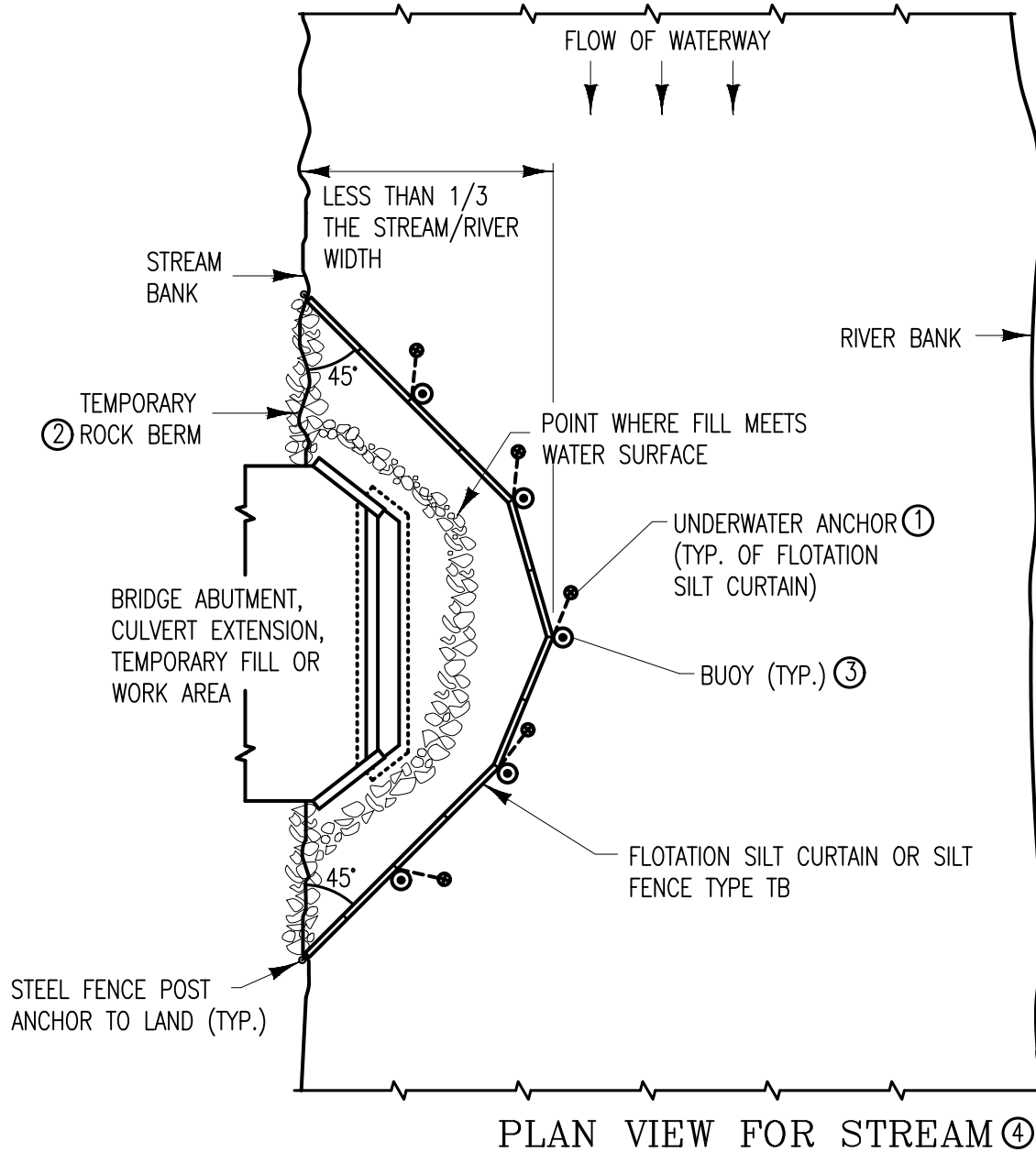

PLAN VIEW FOR STREAM ④

NOTES:

SEE MN/DOT SPECS. 2573, 3886, 3887 & 3893.

- ① FOR ANCHOR SPACING AND WEIGHT REQUIREMENTS, SEE MN/DOT SPEC. 2573.
- ② IN AREAS WHERE THE PLAN CALLS FOR RIPRAP AT A BRIDGE, CULVERT, OR SLOPE, A TEMPORARY ROCK BERM CONSTRUCTED FROM THE RIPRAP CAN BE USED TO PROVIDE ADDITIONAL PROTECTION. WHEN THE WORK IS COMPLETE THE RIPRAP CAN THEN BE MOVED TO THE PERMANENT LOCATION INDICATED IN THE PLANS. THE TEMPORARY ROCK BERM IS INCIDENTAL.
- ③ ON U.S. COAST GUARD OR OTHER MOTORIZED WATERWAYS, BUOYS ARE REQUIRED TO MARK THE ENDS AND SPECIAL AREAS FOR VISIBILITY. PLACE BUOYS AS REQUIRED FOR NAVIGATIONAL PURPOSES.
- ④ SILT CURTAIN SHALL BE REMOVED WHEN THE AREA CONTRIBUTING DIRECT RUNOFF HAS BEEN TEMPORARILY OR PERMANENTLY STABILIZED. SILT CURTAIN SHALL ALSO BE REMOVED BEFORE WINTER IF ICE UP OR ICE FLOW IS ANTICIPATED.

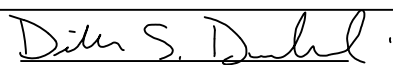
DEPARTMENT OF PUBLIC WORKS CITY OF ROCHESTER, MINNESOTA PLAN VIEW FOR FLOTATION SILT CURTAIN- MOVING WATER			
 CITY ENGINEER			
SHT 1 OF 6 SHTS	DATE REVISED 4/15/21	PLATE NO. 7-02	REV. D

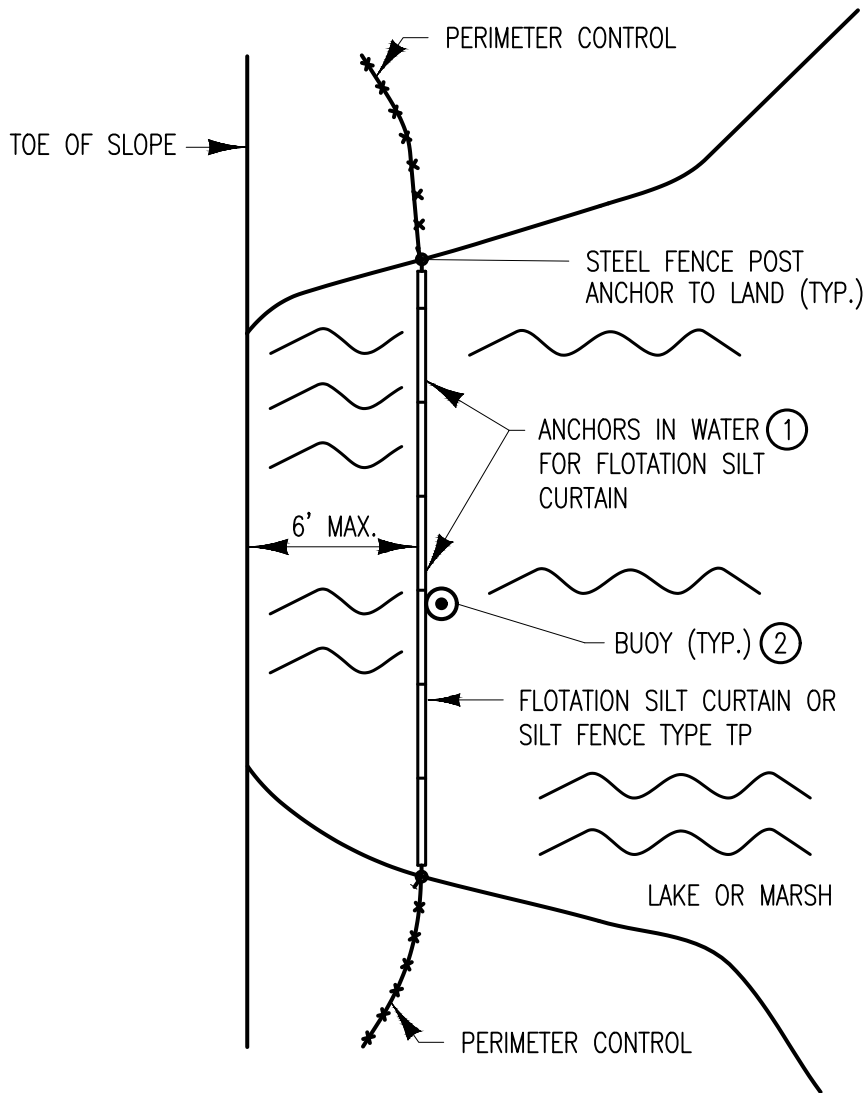

PLAN VIEW FOR LAKE OR MARSH ③

NOTES:

SEE MN/DOT SPECS. 2573, 3886, 3887 & 3893.

- ① FOR ANCHOR SPACING AND WEIGHT REQUIREMENTS, SEE MN/DOT SPEC. 2573.
- ② ON U.S. COAST GUARD OR OTHER MOTORIZED WATERWAYS, BUOYS ARE REQUIRED TO MARK THE ENDS AND SPECIAL AREAS FOR VISIBILITY. PLACE BUOYS AS REQUIRED FOR NAVIGATIONAL PURPOSES.
- ③ SILT CURTAIN SHALL BE REMOVED WHEN THE AREA CONTRIBUTING DIRECT RUNOFF HAS BEEN TEMPORARILY OR PERMANENTLY STABILIZED. SILT CURTAIN SHALL ALSO BE REMOVED BEFORE WINTER IF ICE UP OR ICE FLOW IS ANTICIPATED.

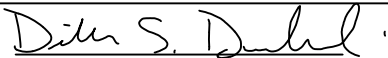
DEPARTMENT OF PUBLIC WORKS CITY OF ROCHESTER, MINNESOTA PLAN VIEW FOR FLOTATION SILT CURTAIN- STILL WATER			
 CITY ENGINEER			
SHT 2 OF 6 SHTS	DATE REVISED 4/15/21	PLATE NO. 7-02	REV. D

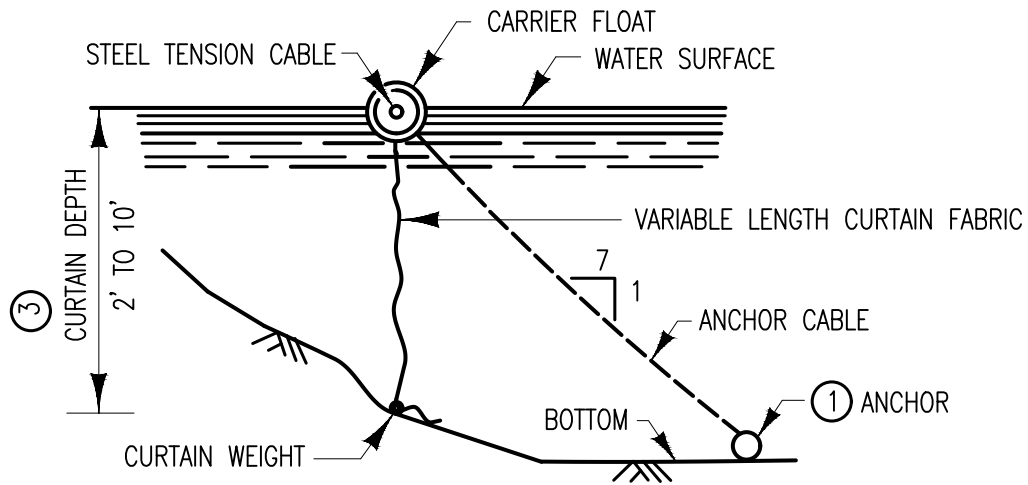

FLOTATION SILT CURTAIN

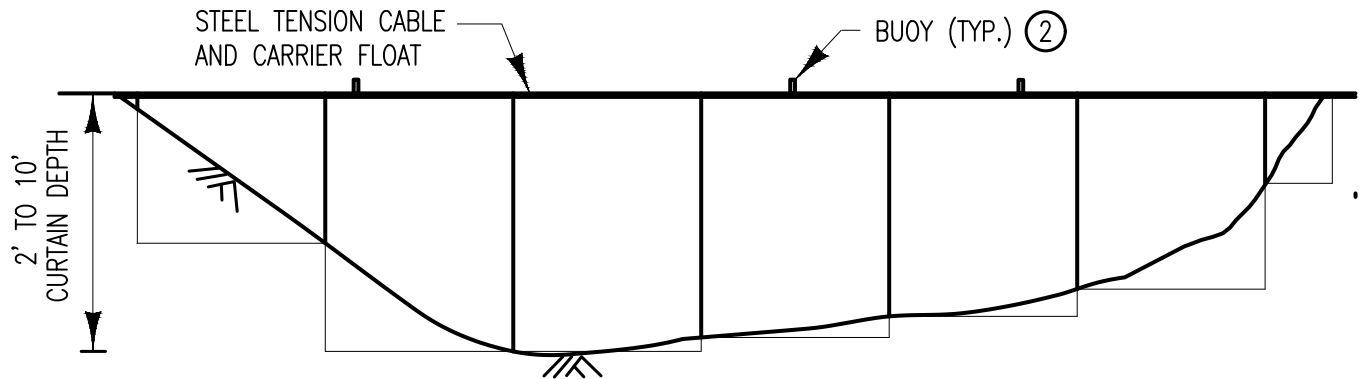

FRONT VIEW FOR FLOTATION SILT CURTAIN

NOTES:

SEE MN/DOT SPECS. 2573, 3886, 3887 & 3893.

- ① FOR ANCHOR SPACING AND WEIGHT REQUIREMENTS, SEE SPEC. 2573.
- ② ON U.S. COAST GUARD OR OTHER MOTORIZED WATERWAYS, BUOYS ARE REQUIRED TO MARK THE ENDS AND SPECIAL AREAS FOR VISIBILITY. PLACE BUOYS AS REQUIRED FOR NAVIGATIONAL PURPOSES.
- ③ MINIMUM WATER DEPTH APPLIES TO THE DEEPEST POINT ALONG THE FLOTATION SILT CURTAIN OR SILT FENCE TYPE TB FOR DETERMINING APPLICABILITY OF FLOTATION SILT CURTAIN OR SILT FENCE TYPE TB.

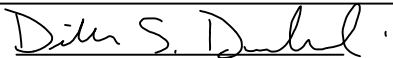
DEPARTMENT OF PUBLIC WORKS CITY OF ROCHESTER, MINNESOTA FLOTATION SILT CURTAIN— WORK AREA & STILL WATER			
 CITY ENGINEER			
SHT 3 OF 6 SHTS	DATE REVISED 4/15/21	PLATE NO. 7-02	REV. D

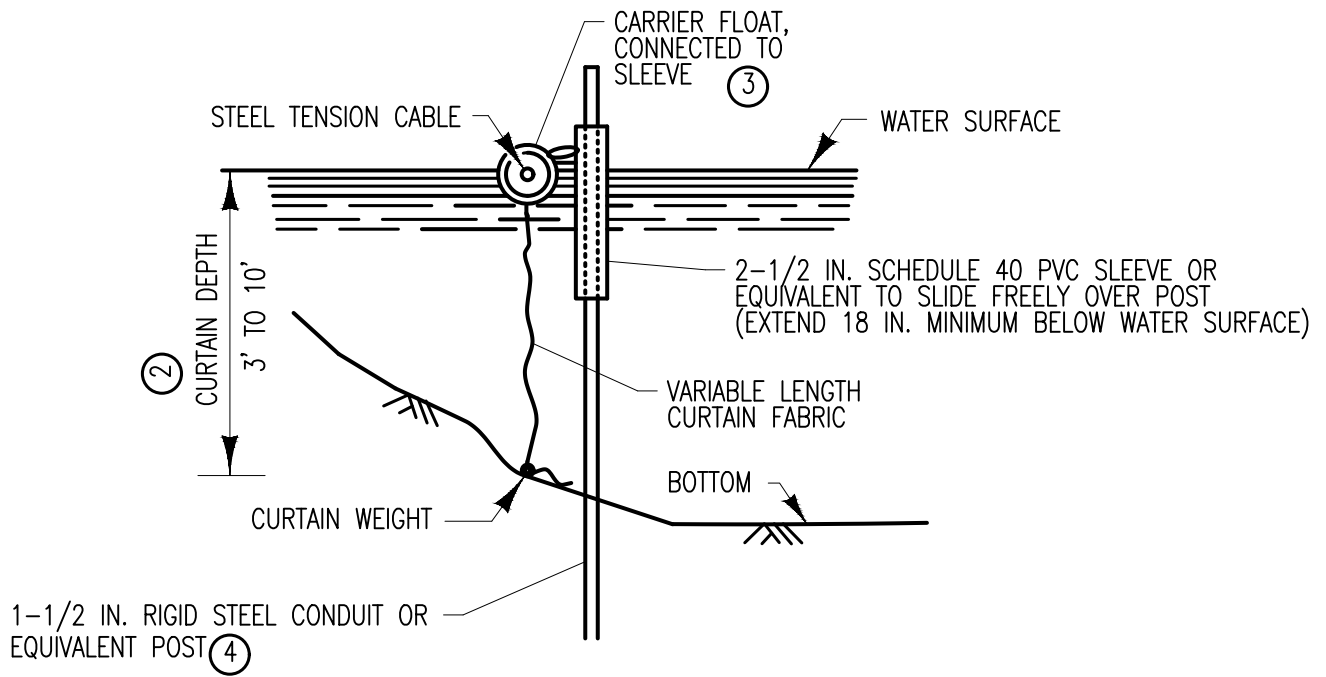

ALTERNATE FLOTATION SILT CURTAIN

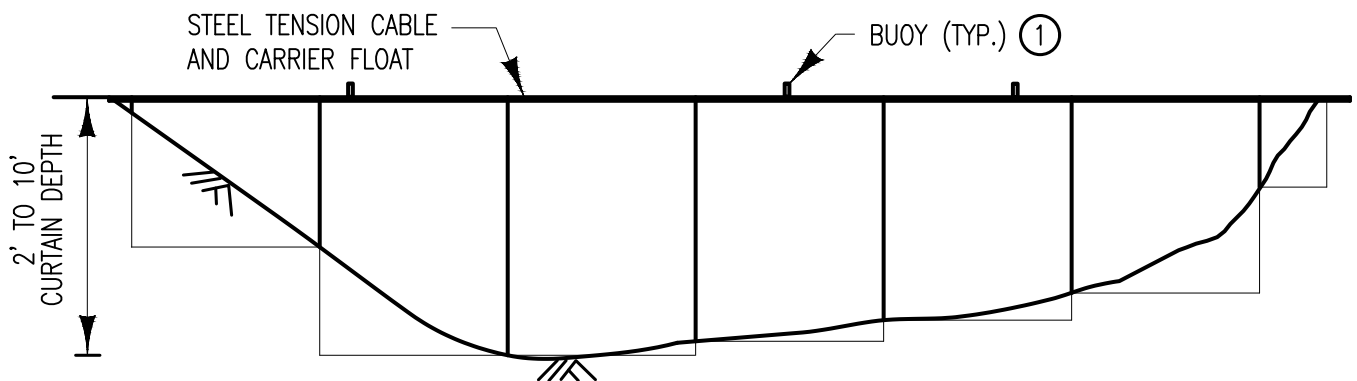

FRONT VIEW FOR FLOTATION SILT CURTAIN

NOTES:

SEE MN/DOT SPECS. 2573, 3886, 3887 & 3893.

- ① ON U.S. COAST GUARD OR OTHER MOTORIZED WATERWAYS, BUOYS ARE REQUIRED TO MARK THE ENDS AND SPECIAL AREAS FOR VISIBILITY. PLACE BUOYS AS REQUIRED FOR NAVIGATIONAL PURPOSES.
- ② MINIMUM WATER DEPTH APPLIES TO THE DEEPEST POINT ALONG THE FLOTATION SILT CURTAIN OR SILT FENCE TYPE TB FOR DETERMINING APPLICABILITY OF FLOTATION SILT CURTAIN OR SILT FENCE TYPE TB.
- ③ ANCHOR FLOAT MUST BE CONNECTED SECURELY TO SLEEVE WITH A MINIMUM TENSILE STRENGTH OF 100 LBS. CONNECTION METHOD MUST ALLOW FOR SLEEVE TO MOVE FREELY ON POST.
- ④ PROVIDE SUFFICIENT NUMBER OF POST ANCHORS TO MAINTAIN SILT CURTAIN POSITION.

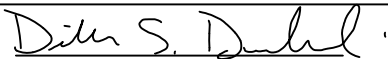
DEPARTMENT OF PUBLIC WORKS CITY OF ROCHESTER, MINNESOTA ALT. SECTIONAL VIEW FLOTATION SILT CURTAIN			
 CITY ENGINEER			
SHT 4 OF 6 SHTS	DATE REVISED 4/15/21	PLATE NO. 7-02	REV. D

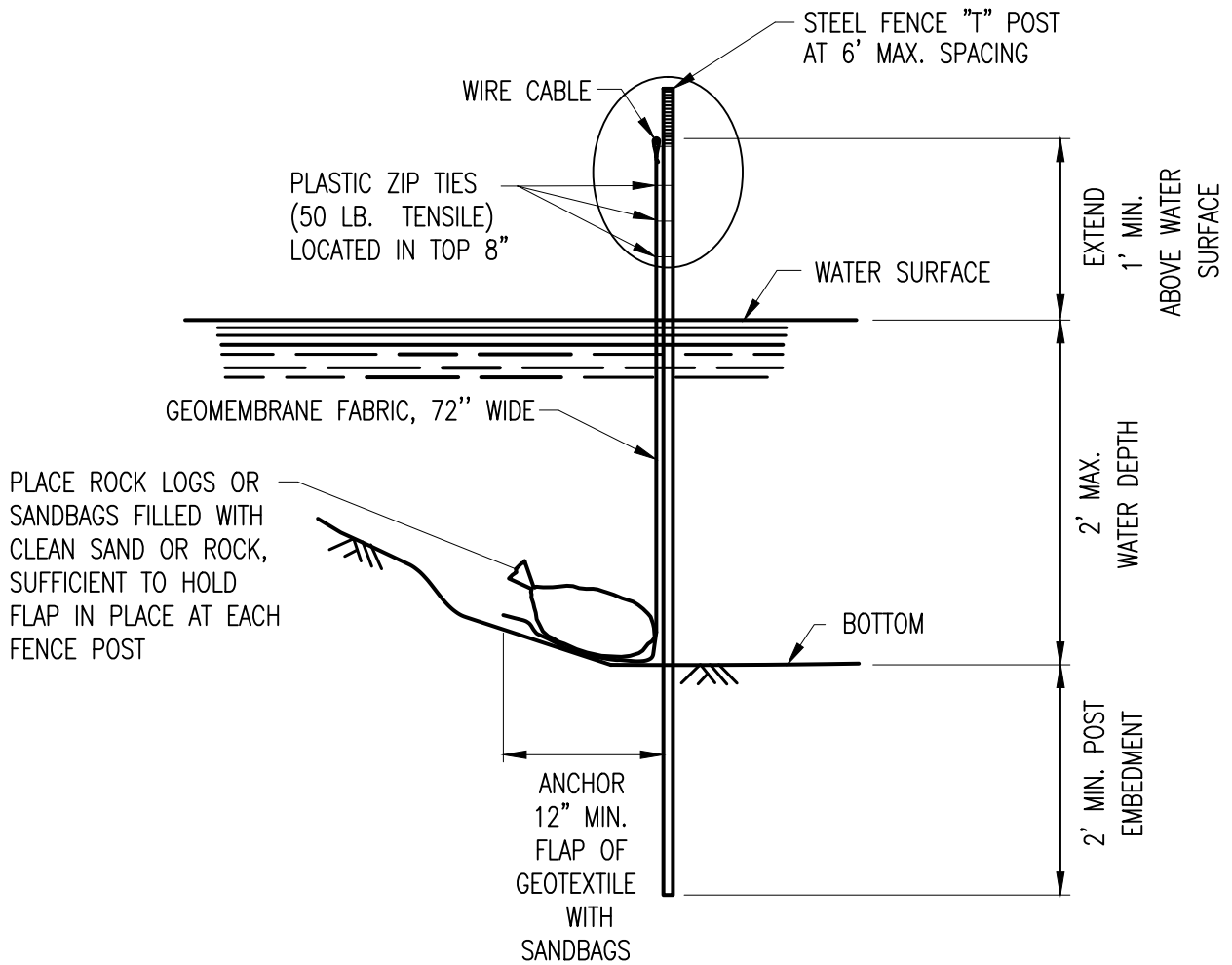

SILT FENCE TYPE TB ①

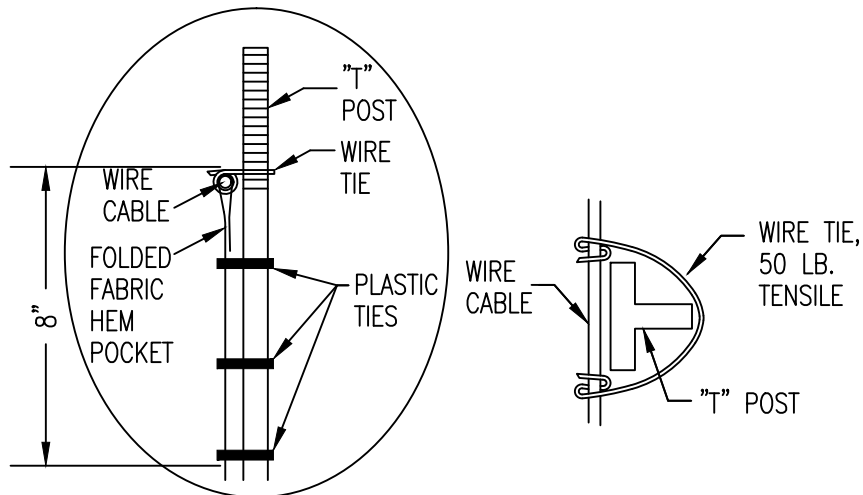

FABRIC/CABLE POST CONNECTION

NOTES:

SEE MN/DOT SPECS. 2573, 3886, 3887 & 3893.

- ① EMBED POST INTO BOTTOM A MINIMUM OF 40% OF THE WATER DEPTH (INCLUDING WAVE HEIGHT), BUT IN NO CASE SHALL EMBEDMENT BE LESS THAN 2 FEET.

DEPARTMENT OF PUBLIC WORKS
CITY OF ROCHESTER, MINNESOTA

SILT FENCE TYPE TB

Dylan S. Dahl
CITY ENGINEER

SHT 5 OF 6 SHTS	DATE REVISED 4/15/21	PLATE NO. 7-02	REV. D
-----------------	-------------------------	-------------------	-----------

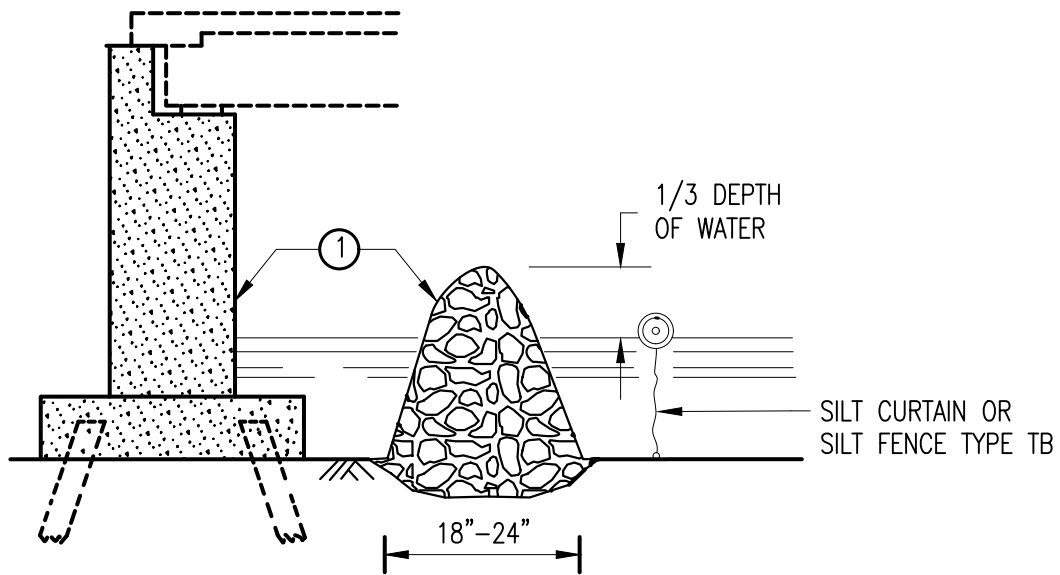

**TEMPORARY ROCK BERM
FOR SEDIMENT CONTROL**

**INSTALLATION GUIDELINES
SILT FENCE TYPE TB**

MINIMUM WATER DEPTH: 1 FOOT
 MAXIMUM WATER DEPTH: 3 FEET
 MAXIMUM WATER VELOCITY: 5 FEET/SECOND

**INSTALLATION GUIDELINES ②
FLOTATION SILT CURTAIN
TYPE: STILL WATER**

MINIMUM WATER DEPTH: 3 FEET
 MAXIMUM WATER DEPTH: 10 FEET
 MAXIMUM WATER VELOCITY: 2 FEET/SECOND
 MAXIMUM WAVE HEIGHT: 1 FOOT

**INSTALLATION GUIDELINES ②
FLOTATION SILT CURTAIN
TYPE: MOVING WATER**

MINIMUM WATER DEPTH: 3 FEET
 MAXIMUM WATER DEPTH: 10 FEET
 MAXIMUM WATER VELOCITY: 5 FEET/SECOND
 MAXIMUM WAVE HEIGHT: 2 FEET

NOTES:

SEE MN/DOT SPECS. 2573, 3886, 3887 & 3893.

① IN AREAS WHERE THE PLAN CALLS FOR RIPRAP AT A BRIDGE, CULVERT, OR SLOPE, A TEMPORARY ROCK BERM CONSTRUCTED FROM THE RIPRAP CAN BE USED TO PROVIDE ADDITIONAL PROTECTION. WHEN THE WORK IS COMPLETE THE RIPRAP CAN THEN BE MOVED TO THE PERMANENT LOCATION INDICATED IN THE PLANS. THE TEMPORARY ROCK BERM IS INCIDENTAL.

② MINIMUM WATER DEPTH APPLIES TO THE DEEPEST POINT ALONG THE FLOTATION SILT CURTAIN OR SILT FENCE TYPE TB FOR DETERMINING APPLICABILITY OF FLOTATION SILT CURTAIN OR SILT FENCE TYPE TB.

DEPARTMENT OF PUBLIC WORKS
 CITY OF ROCHESTER, MINNESOTA
**FLOTATION SILT CURTAIN—
 DESIGN GUIDELINES**

Dylan S. Dahl
 CITY ENGINEER

SHT 6 OF 6 SHTS	DATE REVISED 4/15/21	PLATE NO. 7-02	REV. D
-----------------	-------------------------	-------------------	-----------

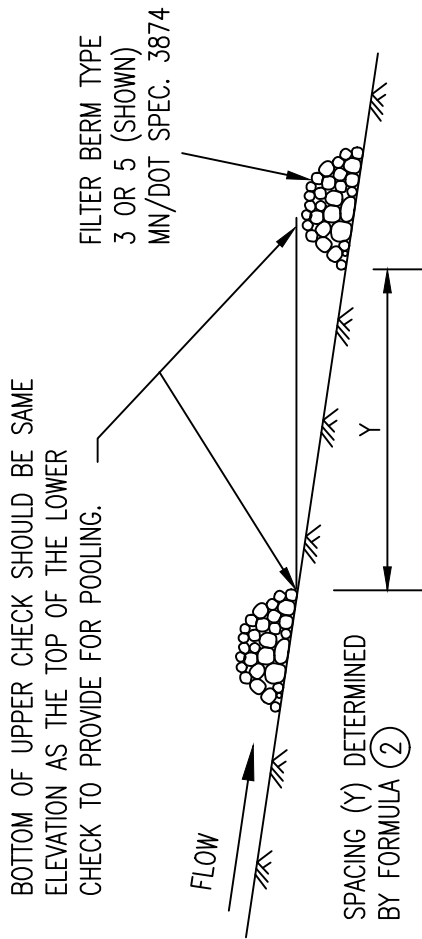

DITCH CHECK SPACING ①

NOTES

SEE MN/DOT SPECS. 2573, 3601, 3733 & 3874

① ROCK DITCH CHECKS PLACED WITHIN THE CLEAR ZONE ARE TO BE 18" OR LESS IN HEIGHT. A 1:6 APPROACH AND DEPARTURE SLOPE SHALL BE PROVIDED.

② APPROXIMATE SPACING BETWEEN EACH DITCH CHECK SHOULD BE DETERMINED FROM SPACING FORMULA:

$$(FT.) = Y = \frac{\text{DITCH CHECK HEIGHT (FT)}}{\% \text{ CHANNEL SLOPE}} \times 100$$

GENERAL DESIGN GUIDELINES		
DITCH CHECK TYPE	ROCK WEEPER	ROCK CHECK
STORM FREQUENCY:	5 YR. - 24 HR.	5 YR. - 24 HR.
MAX. FLOW VELOCITY:	12 FT./SEC	12 FT./SEC
MAX. DITCH GRADE:	3% - 5%	3% - 5%
MAX. DRAINAGE AREA:	4+ ACRE	4+ ACRE

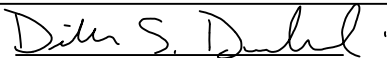
DEPARTMENT OF PUBLIC WORKS CITY OF ROCHESTER, MINNESOTA TEMP. SEDIMENT CONTROL FILTER BERMS			
 CITY ENGINEER			
SHT 1 OF 2 SHTS	DATE REVISED 4/15/21	PLATE NO. 7-03	REV. E

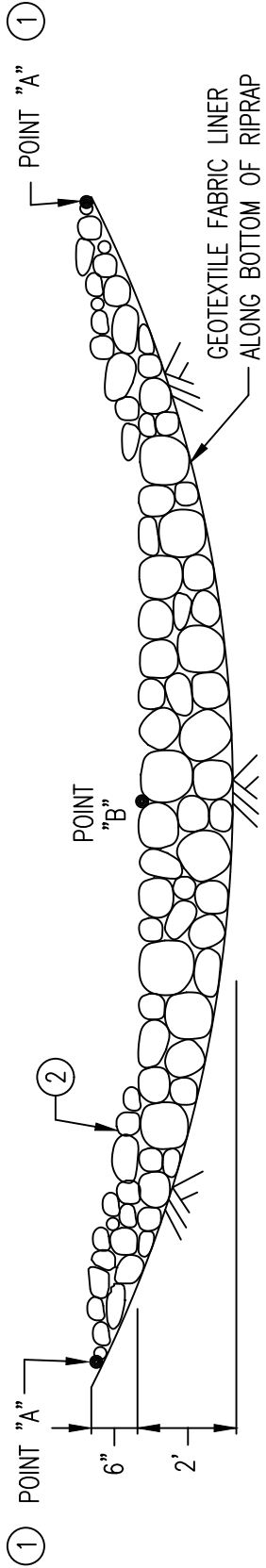

CROSS SECTION (ROCK WEEPER AND ROCK CHECK) (3) (4)
 (ONLY FOR USE OUTSIDE OF CLEAR ZONE)

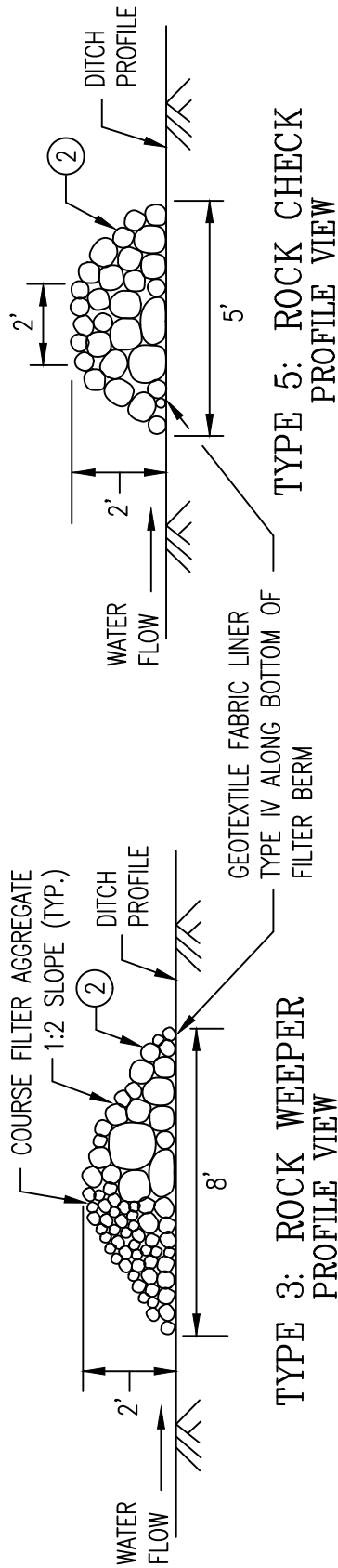

TYPE 3: ROCK WEEPER PROFILE VIEW
 TYPE 5: ROCK CHECK PROFILE VIEW

NOTES

- SEE MN/DOT SPECS. 2573, 3601, 3733, & 3874.
SEE SHEET 1 FOR DITCH CHECK SPACING.
- ① POINT "A" MUST BE A MINIMUM OF 6 INCHES HIGHER THAN POINT "B" TO ENSURE THAT WATER FLOWS OVER THE DIKE AND NOT AROUND THE ENDS.
- ② RIPRAP (MN/DOT SPEC. 3601) ROCK WEEPER - CLASS I, ROCK CHECK - CLASS II
- ③ ROCK DITCH CHECKS PLACED WITHIN THE CLEAR ZONE ARE TO BE 18" OR LESS IN HEIGHT. A 1:6 APPROACH AND DEPARTURE SLOPE SHALL BE PROVIDED.
- ④ DITCH GRADE 3%-5% MAX. FLOW VELOCITY 12 FT./SEC.

DEPARTMENT OF PUBLIC WORKS CITY OF ROCHESTER, MINNESOTA			
TEMP. SEDIMENT CONTROL TYPES 3 & 5 DITCH CHECKS			
<i>Dylan S. Dahl</i> CITY ENGINEER			
SHT 2 OF 2 SHTS	DATE REVISED 4/15/21	PLATE NO. 7-03	REV. E

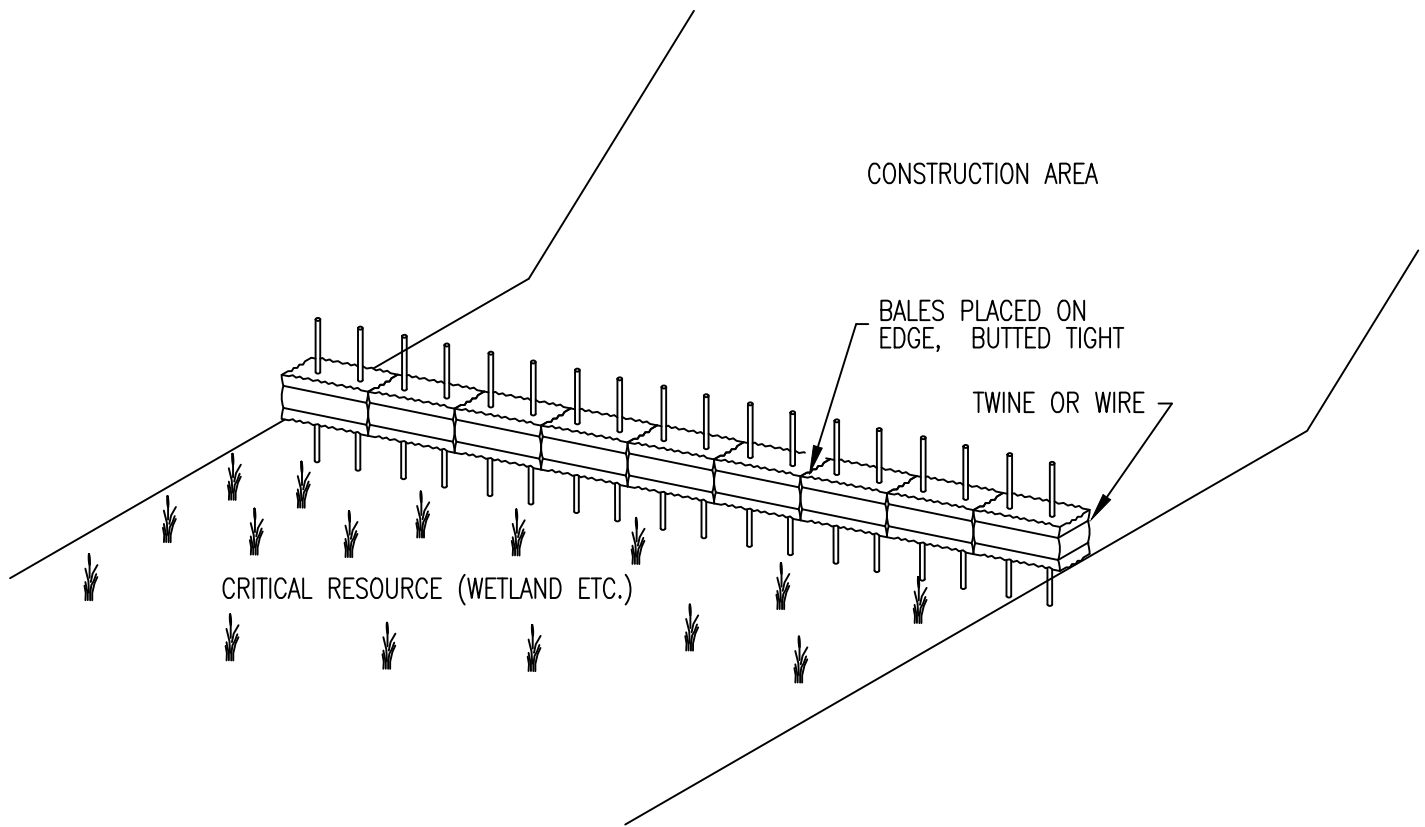

BALE BARRIERS
TO BE USED FOR CRITICAL PERIMETER CONTROL AREAS

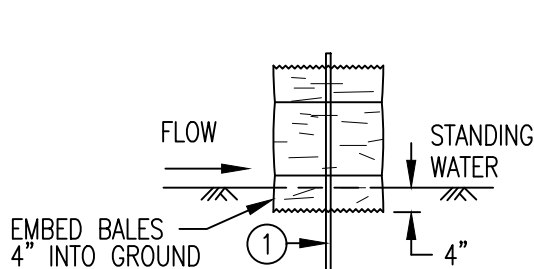

EMBEDMENT METHOD

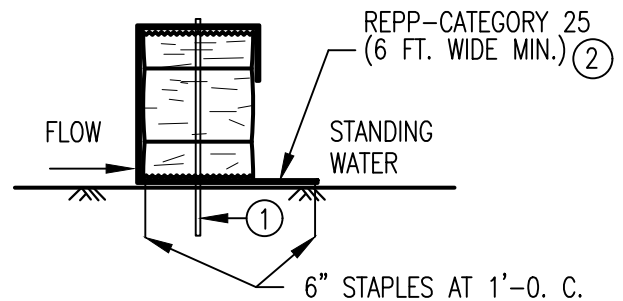

**REPP (BLANKET) METHOD
(ALTERNATE)**

BALE BARRIER DETAIL ③
APPROX. BALE SIZE: 14" X 18" X 36" LONG

NOTES

- SEE MN/DOT SPEC. 2573
- ① TWO 2" X 2" WOOD STAKES OR REINFORCING BARS IN EACH BALE EMBEDDED 10" MINIMUM IN THE GROUND.
- ② INSTEAD OF TRENCHING, PLACE BALE ON THE REPP (BLANKET) AND WRAP BLANKET AROUND THE BALE. PLACE STAKE THROUGH BALE AND BLANKET.
- ③ TO BE USED FOR CRITICAL PERIMETER CONTROL AREAS WHERE STANDING WATER OCCURS (6" MAXIMUM DEPTH). BALES SHALL CONSIST OF TYPE 1 MULCH OF APPROX. 14" X 18" X 36" LONG. BALES SHALL BE PLACED ON EDGE AND BUTTED TIGHT TO ADJACENT BALES.

REPP=ROLLED EROSION PREVENTION PRODUCT

DEPARTMENT OF PUBLIC WORKS CITY OF ROCHESTER, MINNESOTA			
BALE BARRIERS			
<i>Dylan S. Dahl</i> CITY ENGINEER			
SHT 1 OF 1 SHTS	DATE REVISED 4/15/21	PLATE NO. 7-04	REV. E

ENDS SECURELY CLOSED TO PREVENT LOSS OF OPEN GRADED AGGREGATE FILL. SECURED WITH 50 PSI. ZIP TIE.

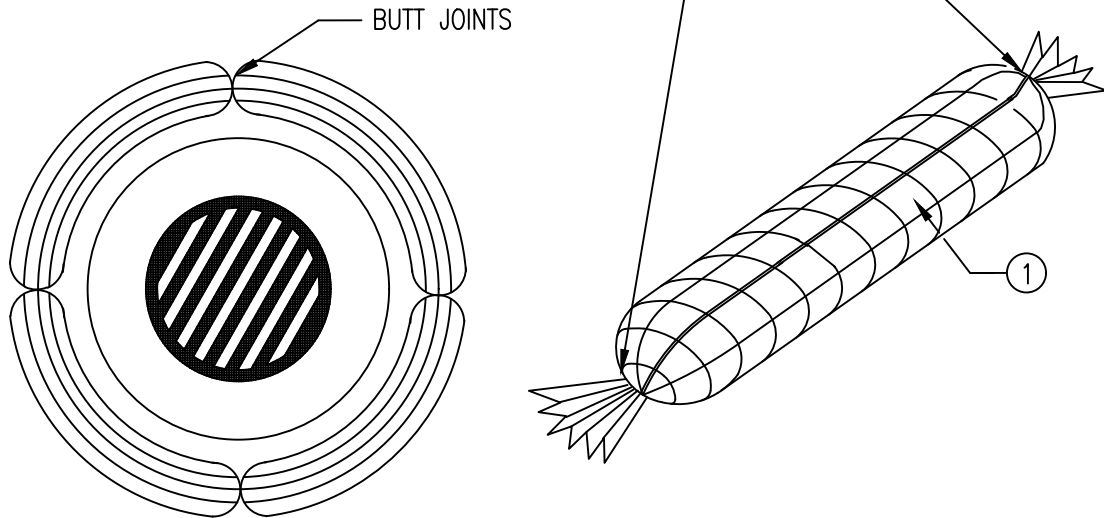

NOTES

SEE MN/DOT SPEC. 2573

MANUFACTURED ALTERNATIVES LISTED ON MN/DOT'S APPROVED PRODUCTS LIST MAY BE SUBSTITUTED.

- ① GEOTEXTILE SOCK BETWEEN 4-10 FEET LONG AND 4-6 INCH DIAMETER. THE SEAM IS TO BE JOINED BY TWO ROWS OF STITCHING WITH A PLASTIC MESH BACKING OR PROVIDE A HEAT BONDED SEAM (OR APPROVED EQUIVALENT). FILL ROCK LOG WITH OPEN GRADED AGGREGATE CONSISTING OF SOUND DURABLE PARTICLES OF COARSE AGGREGATE CONFORMING TO MN/DOT SPEC. 3137 TABLE 3137-1; CA-3 GRADATION.

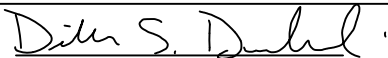
DEPARTMENT OF PUBLIC WORKS CITY OF ROCHESTER, MINNESOTA INLET PROTECTION- ROCK LOG/COMPOST LOG			
 CITY ENGINEER			
SHT 1 OF 5 SHTS	DATE REVISED 4/15/21	PLATE NO. 7-05	REV. E

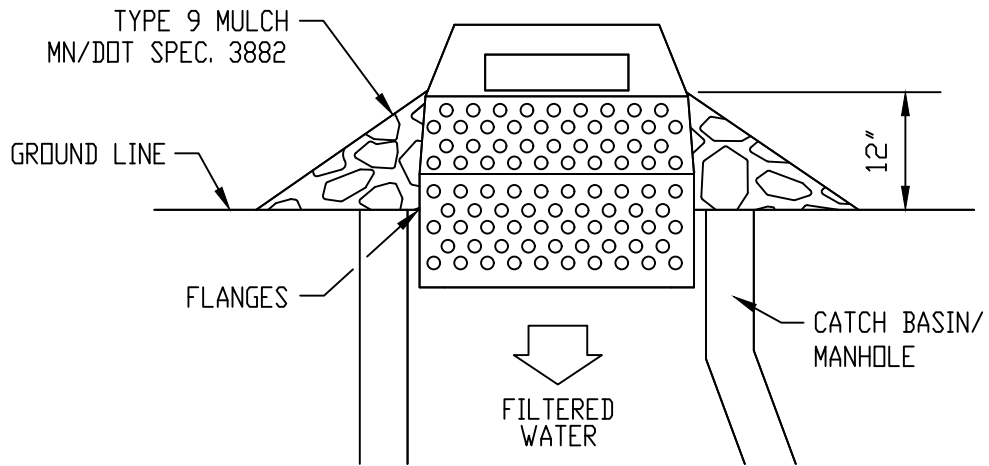

SEDIMENT CONTROL INLET HAT

NOTE:

THE SEDIMENT CONTROL BARRIER SHALL BE A METAL OR PLASTIC/POLYETHYLENE RISER SIZED TO FIT INSIDE THE CATCH BASIN/MANHOLE; HAVE PERFORATIONS TO ALLOW FOR WATER INFILTRATION; HAVE AN OVERFLOW OPENING, FLANGES AND A LID/COVER.

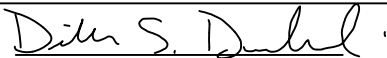
DEPARTMENT OF PUBLIC WORKS CITY OF ROCHESTER, MINNESOTA INLET PROTECTION— SEDIMENT CONTROL INLET HAT			
 CITY ENGINEER			
SHT 2 OF 5 SHTS	DATE REVISED 4/15/21	PLATE NO. 7-05	REV. E

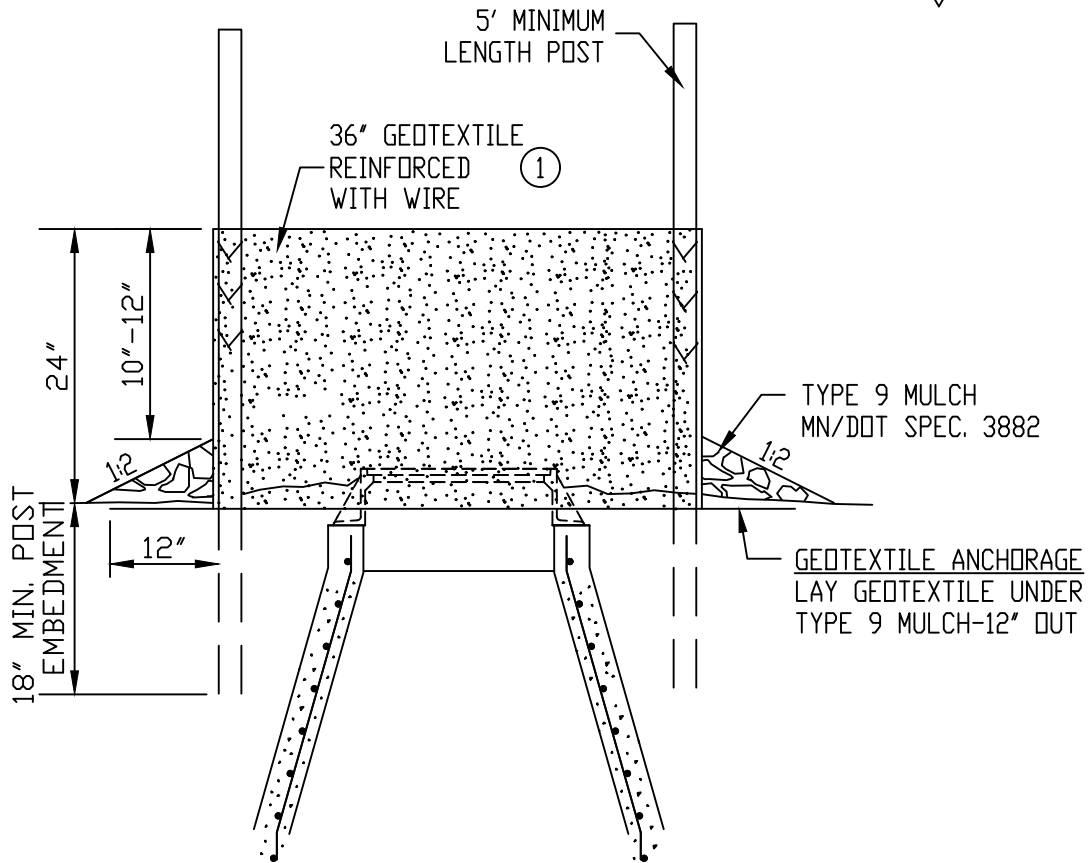
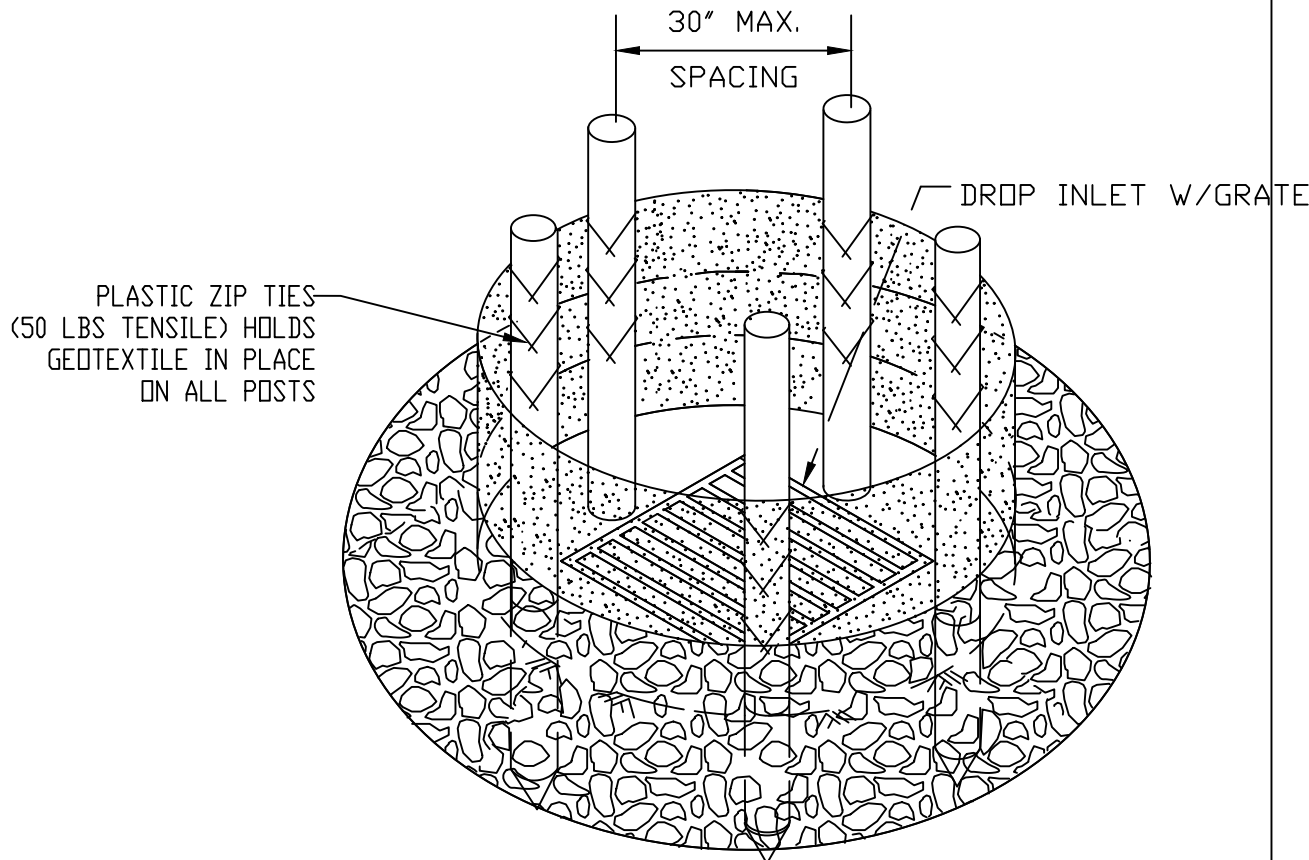

NOTES:

- ① ALL GEOTEXTILE USED FOR INLET PROTECTION SHALL BE MONOFILAMENT IN BOTH DIRECTIONS, MEETING MN/DOT SPEC. 3886.
2. USE WHERE INLET DRAINS AN AREA WITH SLOPES AT 1:3 OR LESS.

DEPARTMENT OF PUBLIC WORKS
 CITY OF ROCHESTER, MINNESOTA
**INLET PROTECTION—
 SILT FENCE RING &
 ROCK FILTER BERM**

Dylan S. Dahl
 CITY ENGINEER

SHT 3 OF 5 SHTS	DATE REVISED 4/15/21	PLATE NO. 7-05	REV. E
-----------------	-------------------------	-------------------	-----------

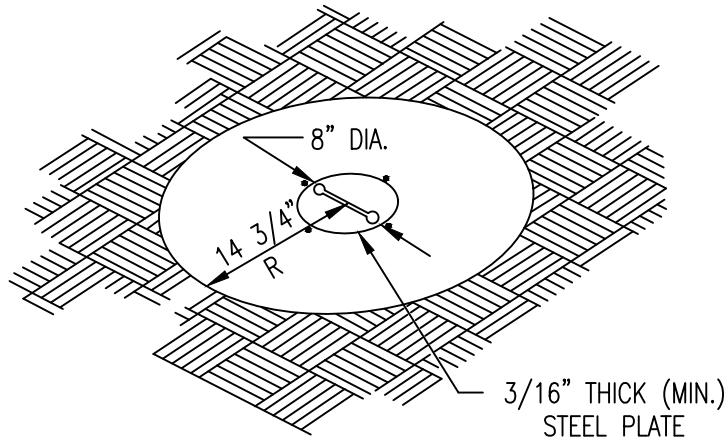

PERSPECTIVE VIEW

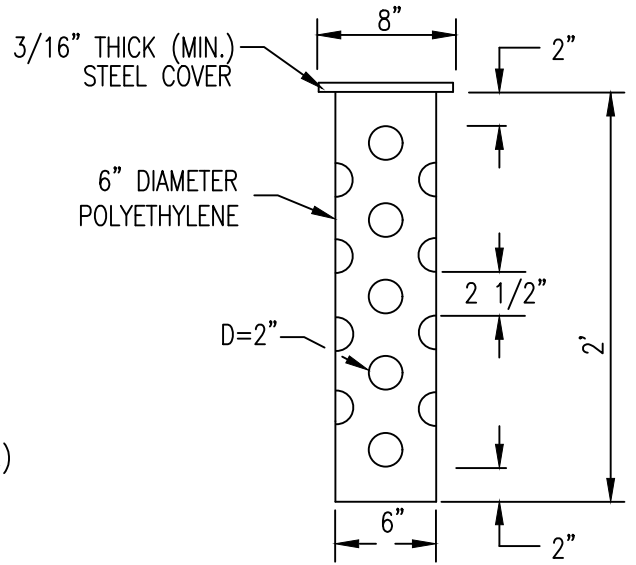

TUBE RISER

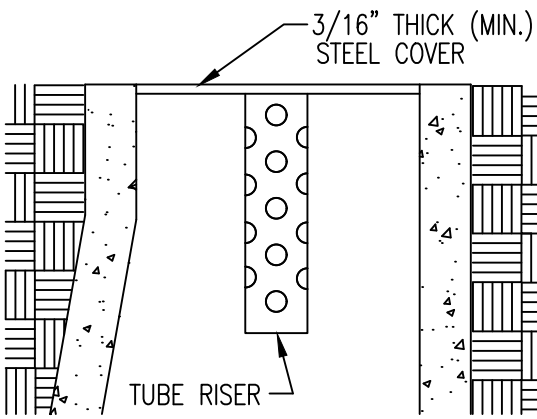

SECTION
(DOWN POSITION)

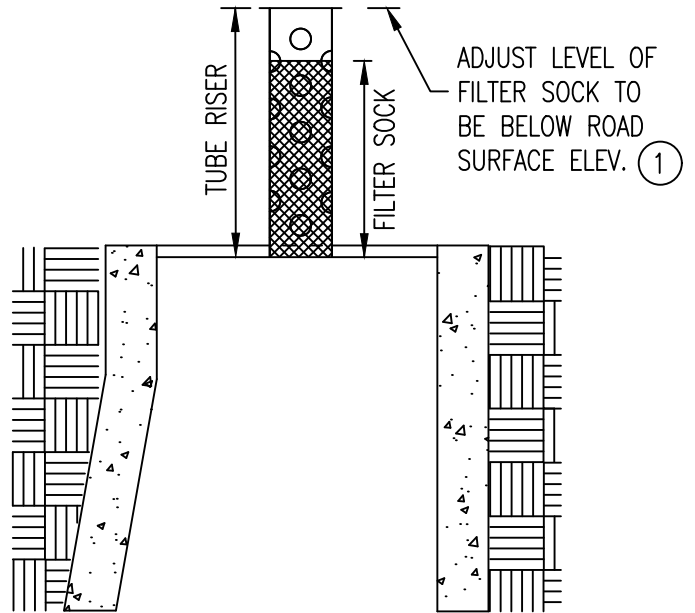

SECTION
(UP POSITION)

NOTES

SEE MN/DOT SPEC. 2573

- ① SOCK HEIGHT MUST NOT BE SO HIGH AS TO SLOW DOWN WATER FILTRATION TO CAUSE FLOODING OF THE ROADWAY.

DEPARTMENT OF PUBLIC WORKS
CITY OF ROCHESTER, MINNESOTA
**INLET PROTECTION—
POP-UP HEAD**

Dylan S. Dahl
CITY ENGINEER

SHT 4 OF 5 SHTS	DATE REVISED 4/15/21	PLATE NO. 7-05	REV. E
-----------------	-------------------------	-------------------	-----------

INLET SPECIFICATIONS AS PER THE PLAN
 DIMENSION LENGTH AND WIDTH TO MATCH
 FLAP POCKET

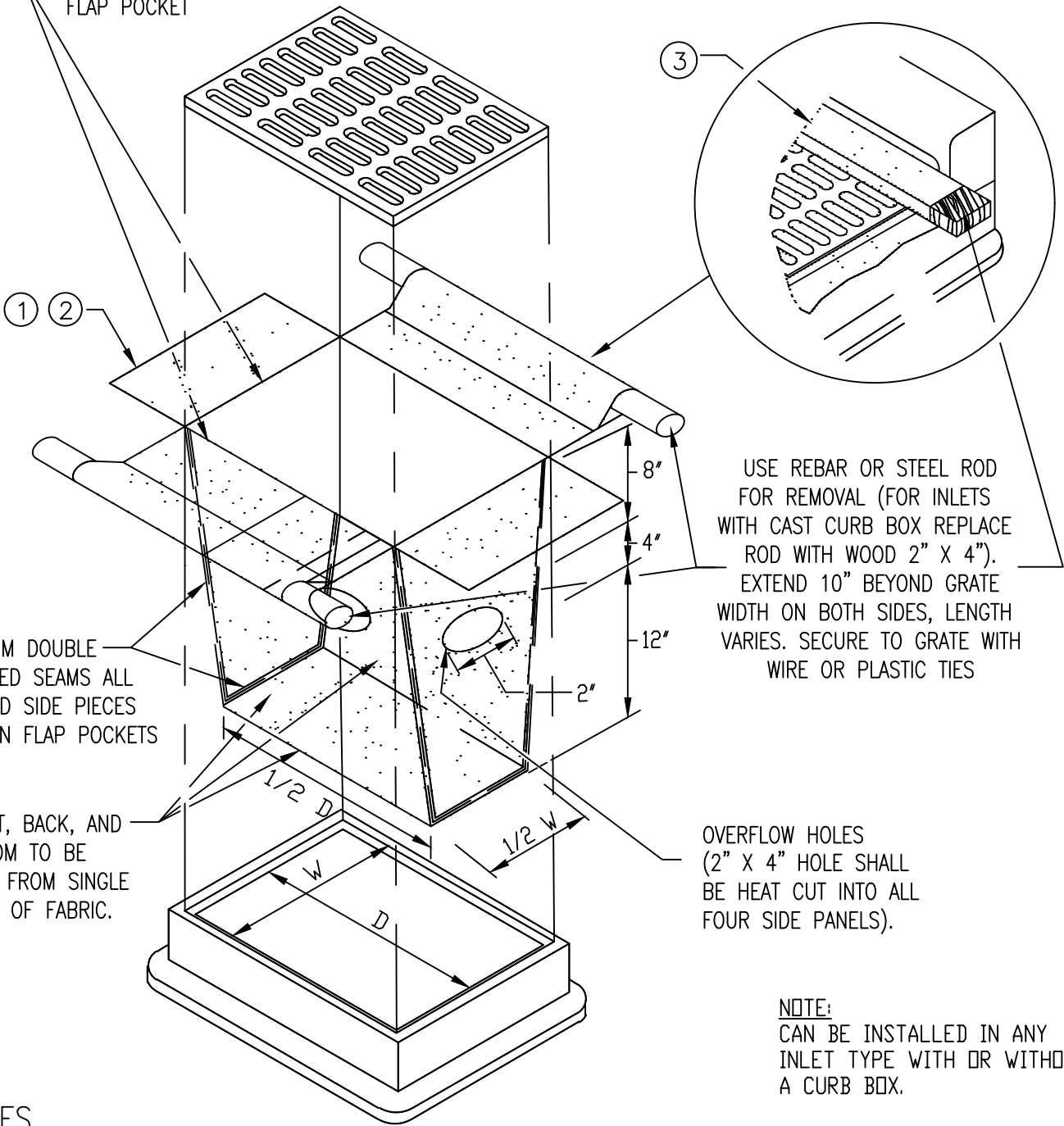

MINIMUM DOUBLE
 STITCHED SEAMS ALL
 AROUND SIDE PIECES
 AND ON FLAP POCKETS

FRONT, BACK, AND
 BOTTOM TO BE
 MADE FROM SINGLE
 PIECE OF FABRIC.

USE REBAR OR STEEL ROD
 FOR REMOVAL (FOR INLETS
 WITH CAST CURB BOX REPLACE
 ROD WITH WOOD 2" X 4").
 EXTEND 10" BEYOND GRATE
 WIDTH ON BOTH SIDES, LENGTH
 VARIES. SECURE TO GRATE WITH
 WIRE OR PLASTIC TIES

OVERFLOW HOLES
 (2" X 4" HOLE SHALL
 BE HEAT CUT INTO ALL
 FOUR SIDE PANELS).

NOTE:
 CAN BE INSTALLED IN ANY
 INLET TYPE WITH OR WITHOUT
 A CURB BOX.

NOTES

- ① ALL GEOTEXTILE USED FOR INLET PROTECTION SHALL BE MONOFILAMENT IN BOTH DIRECTIONS, MEETING MN/DOT SPEC. 3886.
- ② FINISHED SIZE, INCLUDING POCKETS WHERE REQUIRED SHALL EXTEND A MINIMUM OF 10 INCHES AROUND THE PERIMETER TO FACILITATE MAINTENANCE OR REMOVAL.
- ③ FLAP POCKETS SHALL BE LARGE ENOUGH TO ACCEPT WOOD 2 IN. X 4 IN. OR USE A ROCK SOCK OR SAND BAGS IN PLACE OF THE FLAP POCKETS.

4 INSTALLATION NOTES: DO NOT INSTALL FILTER BAG INSERT IN INLETS SHALLOWER THAN 30 IN., MEASURED FROM THE BOTTOM OF THE INLET TO THE TOP OF THE GRATE. THE PLACED BAG SHALL HAVE A MINIMUM SIDE CLEARANCE OF 3" BETWEEN THE INLET WALLS AND THE BAG MEASURED AT THE BOTTOM OF THE OVERFLOW HOLES. WHERE NECESSARY THE CONTRACTOR SHALL CLINCH THE BAG, USING PLASTIC ZIP TIES, TO ACHIEVE THE 3" SIDE CLEARANCE.

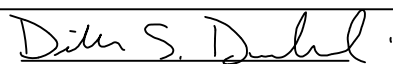
DEPARTMENT OF PUBLIC WORKS CITY OF ROCHESTER, MINNESOTA INLET PROTECTION- FILTER BAG INSERT			
 CITY ENGINEER			
SHT 5 OF 5 SHTS	DATE REVISED 4/15/21	PLATE NO. 7-05	REV. E

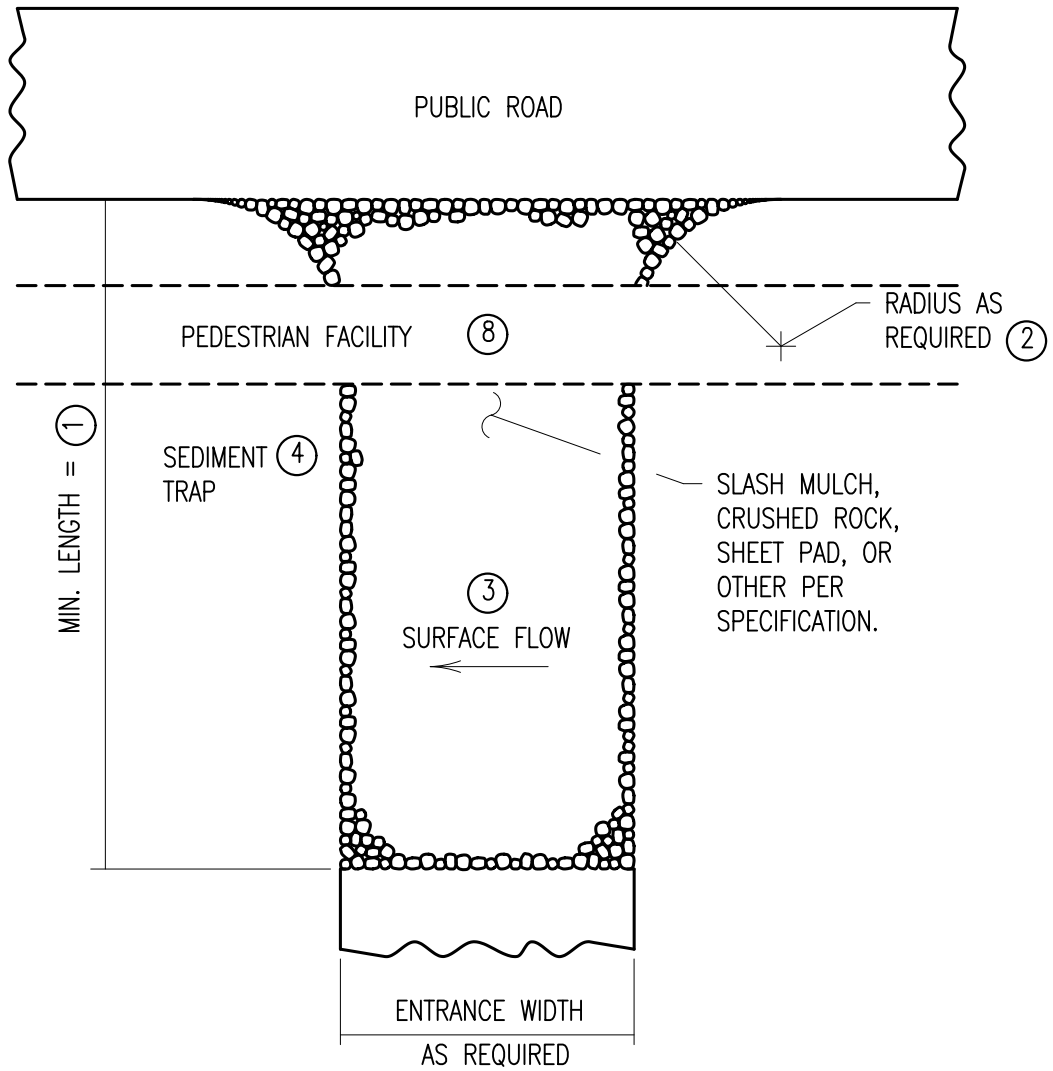

SLASH MULCH, CRUSHED ROCK, OR SHEET PAD CONSTRUCTION EXIT (5) (7)

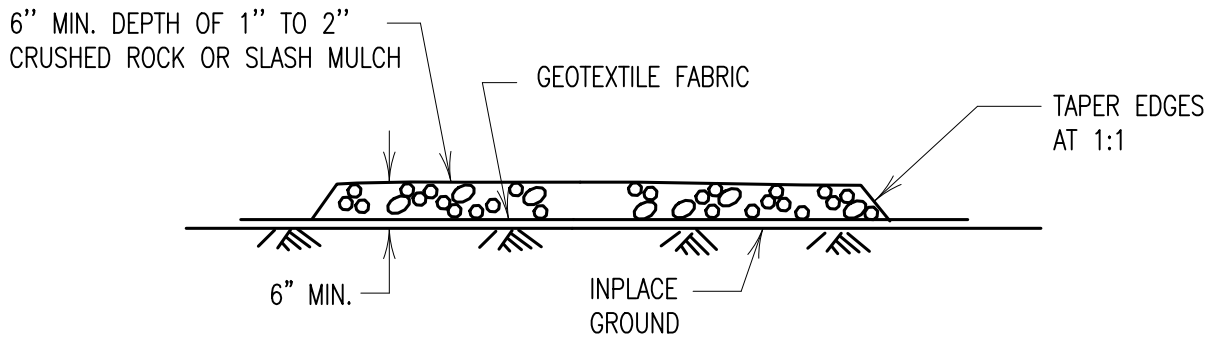

SLASH MULCH OR CRUSHED ROCK

DEPARTMENT OF PUBLIC WORKS CITY OF ROCHESTER, MINNESOTA SLASH MULCH, CRUSHED ROCK, OR SHEET PAD CONSTRUCTION EXITS			
<i>Dylan S. Dahl</i> CITY ENGINEER			
SHT 1 OF 3 SHTS	DATE REVISED 1/1/23	PLATE NO. 7-06	REV. F

SEE SHEET 2 OF 3 FOR DETAIL NOTES

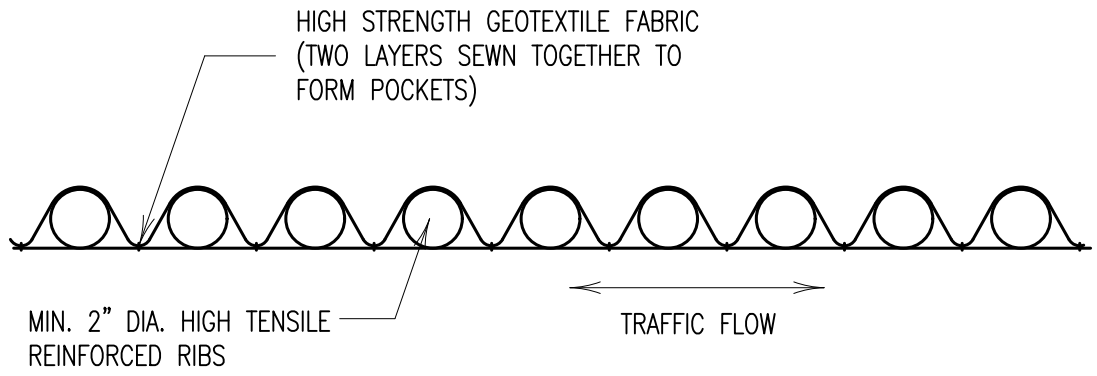

SHEET PAD

NOTES:

SEE MN/DOT SPECS. 2573 & 3882.

- ① MINIMUM LENGTH SHALL BE THE GREATER OF 50 FEET OR A LENGTH SUFFICIENT TO ALLOW A MINIMUM OF 5 TIRE ROTATIONS ON THE PROVIDED PAD. MINIMUM LENGTH SHALL BE CALCULATED USING THE LARGEST TIRE WHICH WILL BE USED IN TYPICAL OPERATIONS.
- ② PROVIDE RADIUS OR WIDEN PAD SUFFICIENTLY TO PREVENT VEHICLE TIRES FROM TRACKING OFF OF PAD WHEN LEAVING SITE.
- ③ IF RUNOFF FROM DISTURBED AREAS FLOWS TOWARD CONSTRUCTION EXITS, PREVENT RUNOFF FROM DRAINING DIRECTLY TO PUBLIC ROAD OVER CONSTRUCTION EXIT BY CROWNING THE EXIT OR SLOPING TO ONE SIDE. IF SURFACE GRADING IS INSUFFICIENT, PROVIDE OTHER MEANS OF INTERCEPTING RUNOFF.
- ④ IF RUNOFF FROM CONSTRUCTION EXITS WILL DRAIN OFF OF PROJECT SITE, PROVIDE SEDIMENT TRAP WITH STABILIZED OVERFLOW.
- ⑤ IF A TIRE WASH OFF IS REQUIRED THE CONSTRUCTION EXITS SHALL BE GRADED TO DRAIN THE WASH WATER TO A SEDIMENT TRAP.
- ⑥ MINIMUM LENGTH OF RUMBLE PAD SHALL BE 20 FEET, OR AS REQUIRED TO REMOVE SEDIMENT FROM TIRES. IF SIGNIFICANT SEDIMENT IS TRACKED FROM THE SITE, THE RUMBLE PAD SHALL BE LENGTHENED OR THE DESIGN MODIFIED TO PROVIDE ADDITIONAL VIBRATION. WASH-OFF LENGTH SHALL BE AS REQUIRED TO EFFECTIVELY REMOVE CONSTRUCTION SEDIMENT FROM VEHICLE TIRES.
- ⑦ MAINTENANCE OF CONSTRUCTION EXITS SHALL OCCUR WHEN THE EFFECTIVENESS OF SEDIMENT REMOVAL HAS BEEN REDUCED. MAINTENANCE SHALL CONSIST OF REMOVING SEDIMENT AND CLEANING THE MATERIALS OR PLACING ADDITIONAL MATERIAL (SLASH MULCH OR CRUSHED ROCK) OVER SEDIMENT FILLED MATERIAL TO RESTORE EFFECTIVENESS.
- ⑧ EXISTING PEDESTRIAN FACILITY SHALL BE MAINTAINED TO PROVIDE A PASSABLE SURFACE FOR PEDESTRIANS.
9. CLEAN PAVED STREETS AND PEDESTRIAN FACILITIES AT THE END OF EACH WORKING DAY, OR MORE FREQUENTLY AS NECESSARY TO PROVIDE SAFETY TO THE TRAVELING PUBLIC.

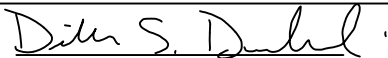
DEPARTMENT OF PUBLIC WORKS CITY OF ROCHESTER, MINNESOTA TEMP. SEDIMENT CONTROL CONSTRUCTION EXITS			
 CITY ENGINEER			
SHT 2 OF 3 SHTS	DATE REVISED 1/1/23	PLATE NO. 7-06	REV. F

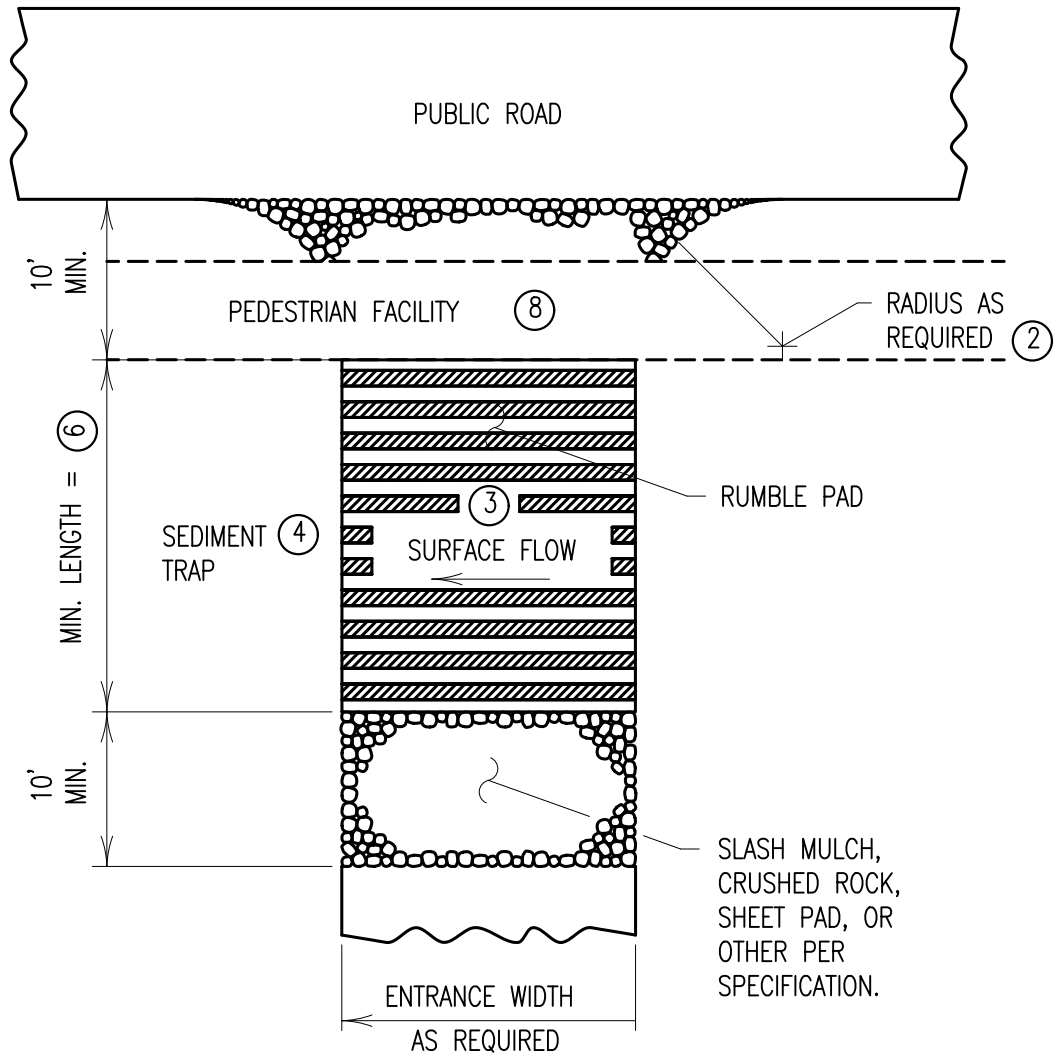

**RUMBLE PAD
CONSTRUCTION EXIT (5)(7)**

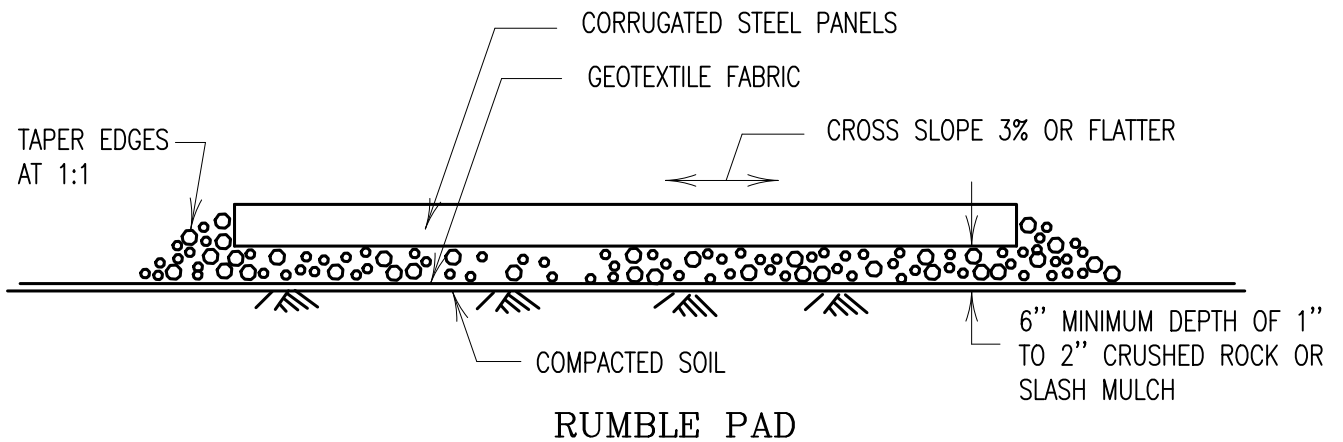

RUMBLE PAD

DEPARTMENT OF PUBLIC WORKS
CITY OF ROCHESTER, MINNESOTA
**RUMBLE PAD
CONSTRUCTION EXITS**

Dylan S. Dahl
CITY ENGINEER

SEE SHEET 2 OF 3 FOR DETAIL NOTES

SHT 3 OF 3 SHTS	DATE REVISED 1/1/23	PLATE NO. 7-06	REV. F
-----------------	------------------------	-------------------	-----------

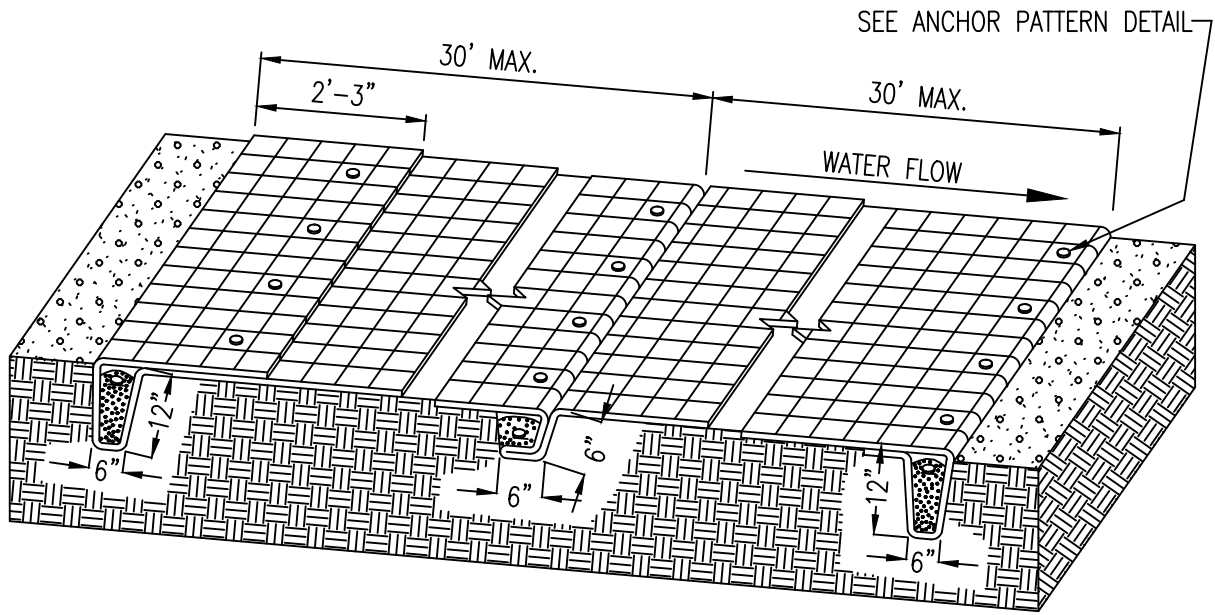

TERMINAL CHANNEL ANCHOR TRENCH

INTERMITTENT CHECK SLOT

INITIAL CHANNEL ANCHOR TRENCH

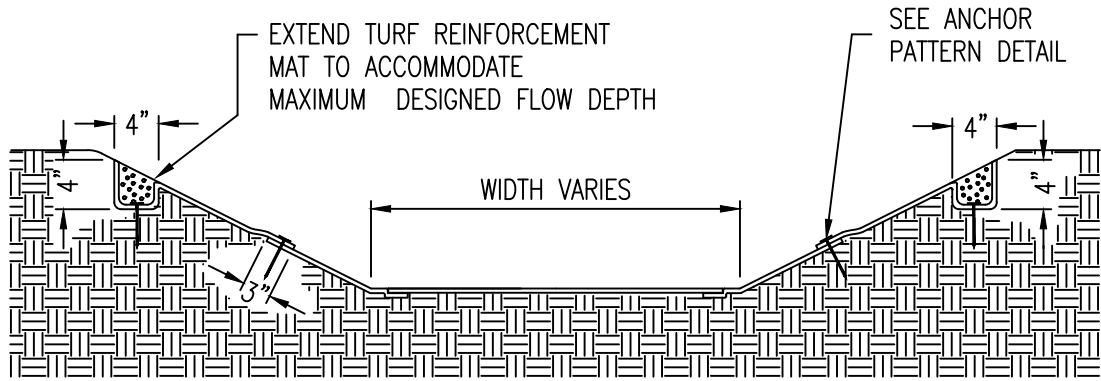

TYPICAL CHANNEL LAYOUT

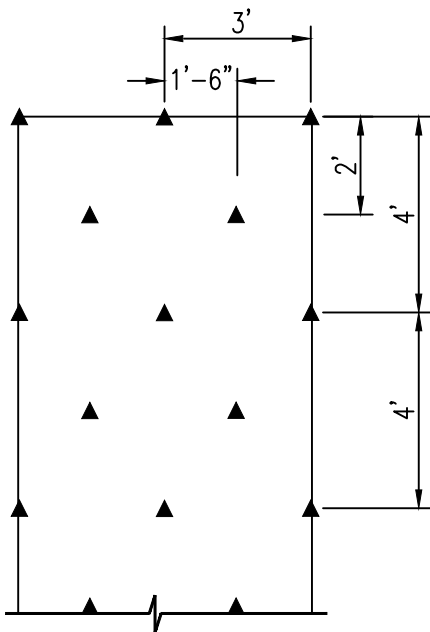

ANCHOR PATTERN

PATTERN AS SHOWN OR PER MANUFACTURER REQUIREMENTS, WHICHEVER IS MORE STRINGENT.

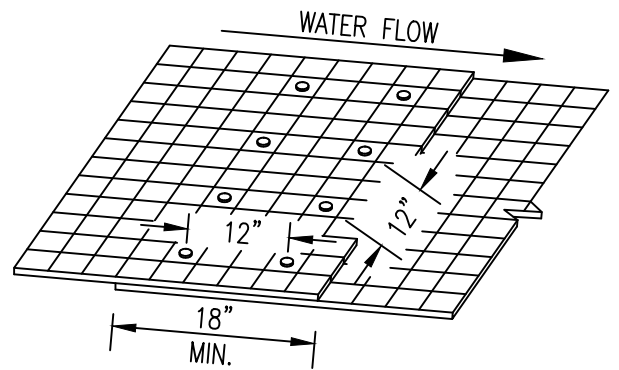

ANCHOR PATTERN AT LAP JOINTS

DEPARTMENT OF PUBLIC WORKS CITY OF ROCHESTER, MINNESOTA TURF REINFORCEMENT MAT FOR CHANNELS			
<i>Douglas L. Nelson</i> ASST. CITY ENGINEER		<i>Reuel W. Frenn</i> DIRECTOR	
SHT 1 OF 1 SHTS	DATE REVISED 4/16/01	PLATE NO. 7-07	REV. A

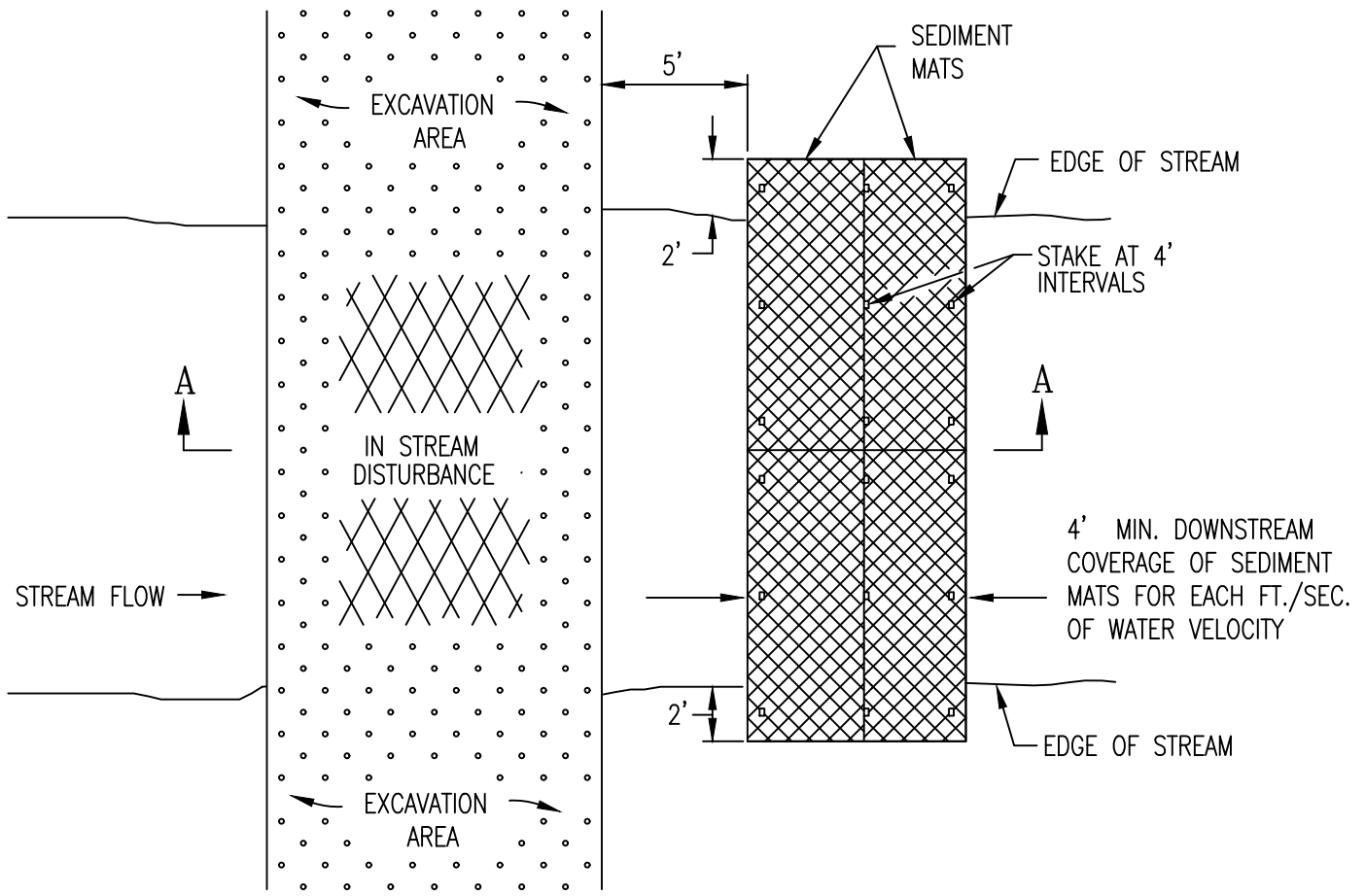

PLAN VIEW

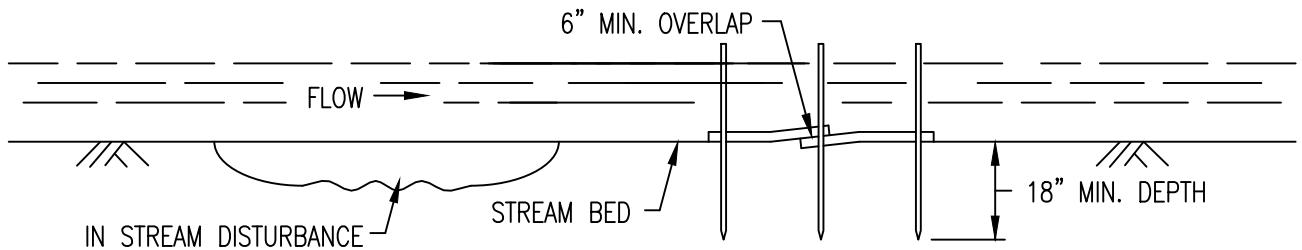

SECTION A-A

DESIGN GUIDELINES:

MAXIMUM FLOW VELOCITY: 5 FEET/SECOND
 MAXIMUM FLOW DEPTH: 2 FEET

NOTES

SEE MN/DOT SPEC. 2573

- ① THIS DETAIL MAY NOT BE ACCEPTABLE FOR WORK ON PUBLIC WATERS, SEE GENERAL PUBLIC WATERS PERMIT (GP) 2004-0001.

DEPARTMENT OF PUBLIC WORKS CITY OF ROCHESTER, MINNESOTA			
SEDIMENT MAT			
<i>Douglas Nelson</i> ASST. CITY ENGINEER		<i>Keith W. Frenn</i> DIRECTOR	
SHT 1 OF 1 SHTS	DATE REVISED 1/20/17	PLATE NO. 7-08	REV. B

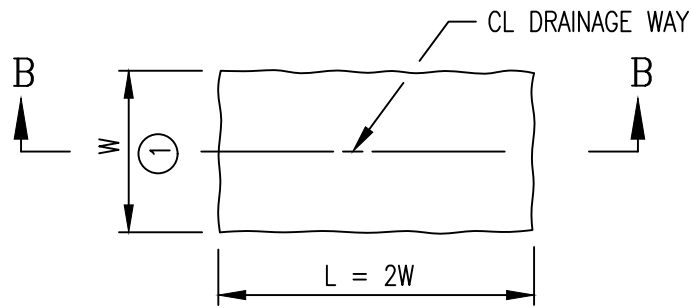

PLAN

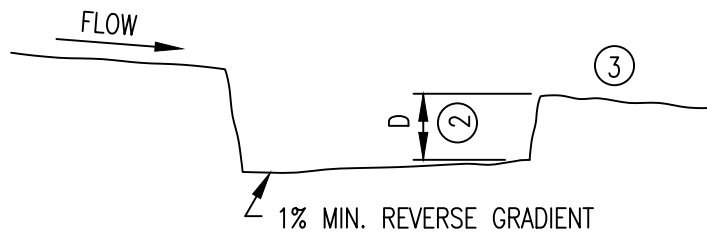

SECTION B-B

NOTES

SEE SPECS. 2573

- ① W=10 FEET MINIMUM, 20 FEET MAXIMUM
- ② D=2 FEET
- ③ LOCATION OF DOWNSTREAM TEMPORARY SEDIMENT CONTROL DEVICE.

DEPARTMENT OF PUBLIC WORKS CITY OF ROCHESTER, MINNESOTA			
SEDIMENT TRAP DETAIL			
<i>Douglas Nelson</i> ASST. CITY ENGINEER		<i>Reed W. Frenn</i> DIRECTOR	
SHT 1 OF 1 SHTS	DATE REVISED 6/15/07	PLATE NO. 7-09	REV. A